

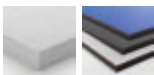

5387 TFZ P						HW		
PÍLOVÉ KOTUČE NA NEŽELEZNÉ KOVY - TRAPÉZ POZ.								
ø D	B	b	ø d	Z	Nr			
200	3,2	2,5	30	48	2218711P200			
250	3,2	2,5	30	60	2218711P250			
300	3,2	2,5	30	96	2218711P300			
350	3,6	2,8	30	108	2218711P350			
400	3,6	2,8	30	96	2218711P400			



Určené na hliník, plast, HPL dosky. Rezanie plných materiálov. Strojný posuv.



5387 TFZ N						HW		
PÍLOVÉ KOTUČE NA NEŽELEZNÉ KOVY - TRAPÉZ NEG.								
ø D	B	b	ø d	Z	Nr			
200	3,2	2,5	30	60	2218711N200			
250	3,2	2,5	30	80	2218711N250			
300	3,2	2,5	30	96	2218711N300			
350	3,6	2,8	30	108	2218711N350			
400	3,6	2,8	30	120	2218711N400			



Určené na hliník, plast, HPL dosky. Rezanie tenkostenných materiálov. Vhodné aj na ručný posuv.



5388 WZ/FA - DRY CUT						HW		
PÍLOVÉ KOTUČE NA OCEĽ A KOMPOZITY								
ø D	B	b	ø d	Z	Nr	€		
200	2,4	1,8	30	40	22188WF0200	30,70		
216	2,4	1,8	30	40	22188WF0216	37,10		
250	2,4	2	30	48	22188WF0250	43,80		
300	2,4	2	30	60	22188WF0300	52,20		
300	2,4	2	30	80	22188WF0301	59,10		
305	2,4	2	30	80	22188WF0305	59,10		
350	2,6	2	30	80	22188WF0350	63,00		

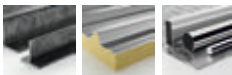

Určené na abrazívne materiály, tenkostenné oceľové profily, sendvičové materiály.

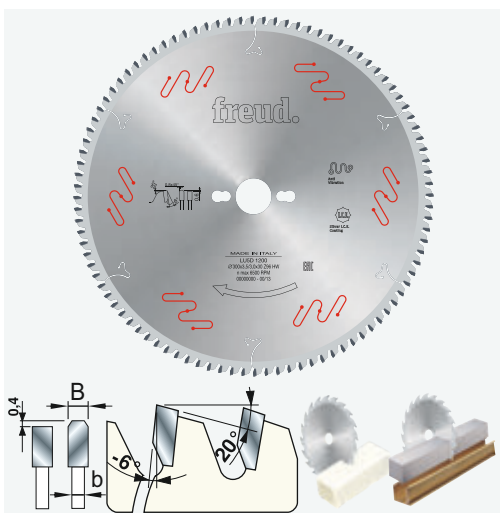

LU5D TFZN						HW		
PÍLOVÉ KOTUČE NA NEŽELEZNÉ MATERIÁLY A PVC								
ø D	B	b	ø d	Z	Nr			
230	3	2,5	30	64	280LU5D0700			
250	3,5	3	30	80	280LU5D0800			
300	3,5	3	30	96	280LU5D1200			
330	3,5	3	30	104	280LU5D1500			
350	3,5	3	30	108	280LU5D1700			
400	3,5	3	30	120	280LU5D2300			
450	4	3,2	30	128	280LU5D2900			
500	4	3,2	30	140	280LU5D3400			



Pílové kotuče prevažne na skracovanie ťahaných profilov z neželezných kovov a plastov s hrúbkou steny nepresahujúcou 3mm.

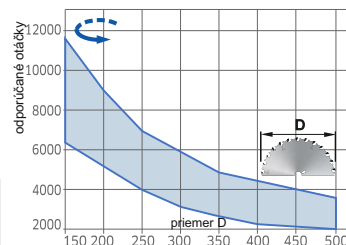

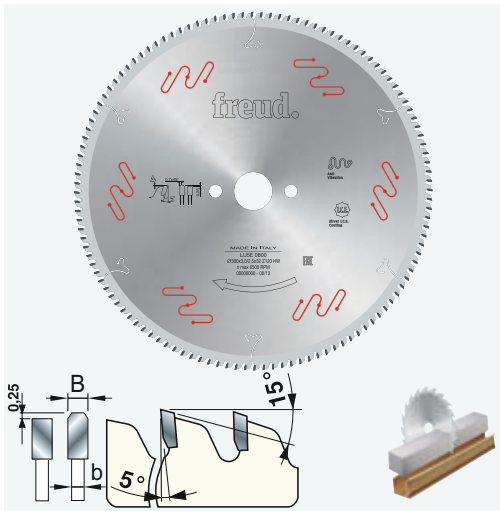

LU5E TFZ **HW** **freud**
PÍLOVÉ KOTUČE NA NEŽELEZNÉ MATERIÁLY

ø D	B	b	ø d	Z	Nr
250	2,8	2,2	32	100	280LU5E0200
255	2,8	2,2	25,4	100	280LU5E0300
300	3	2,5	30	100	280LU5E0500
300	3	2,5	30	120	280LU5E0700
305	3	2,5	25,4	120	280LU5E0600
350	3	2,5	30	100	280LU5E0900
350	3	2,5	30	120	280LU5E1100



Pílové kotúče na rezanie tenkostenných profilov z hliníka a neželezných kovov. Potrebná mechanická fixácia rezaného materiálu.

