

BLANKET

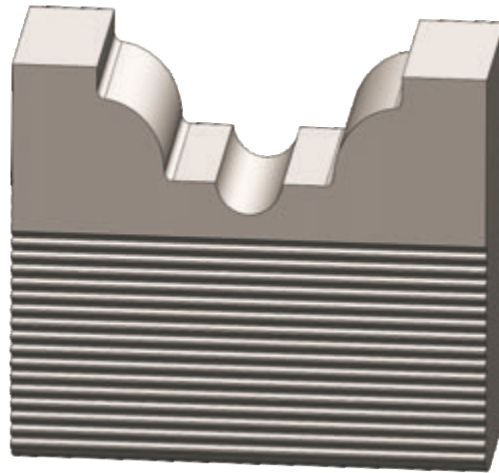

BLANKET

HS
HW

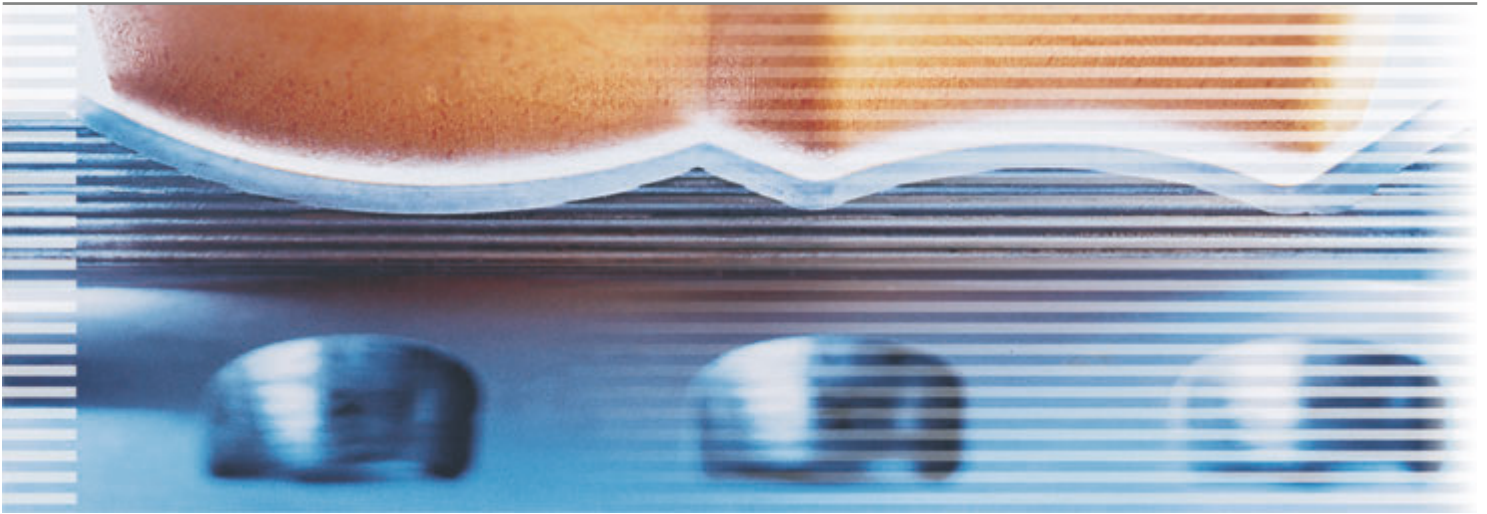
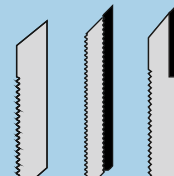

BLANKET 8

HS (18%W)

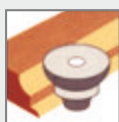
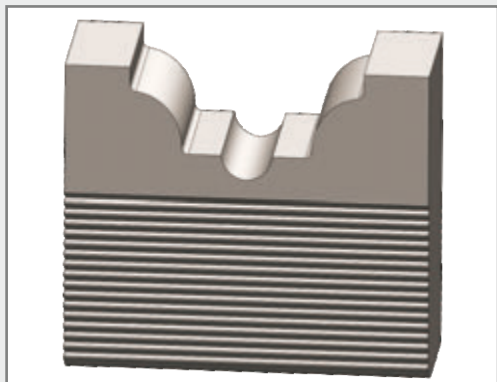

- profesionálne profilové nože pre obrábanie masívu
- ustavovanie pomocou fixačného ryhovania bez prípravkov a meradiel
- ostrenie po čele a chrbte
- nasadzovanie do frézovačiek so strojným posuvom
- **ceny sú uvedené za ľubovoľný profil** nezávisle na jeho zložitosti

B	h	t	Nr
40	50	15	222203
60	50	15	222205
80	50	15	222207
100	50	15	222214
130	50	15	222209
150	50	15	2222102
180	50	15	2222106
230	50	15	222211

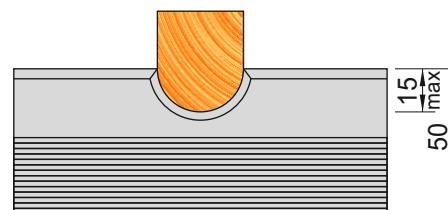

B	h	t	Nr
40	70	35	222204
60	70	35	222206
80	70	35	222208
100	70	35	222215
130	70	35	222210
150	70	35	2222101
180	70	35	2222107
230	70	35	222213

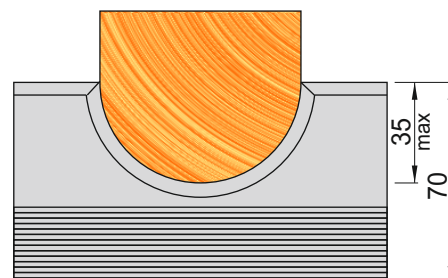
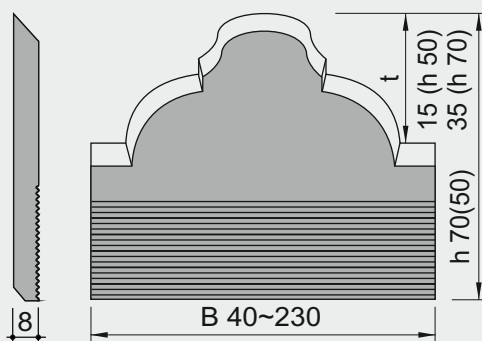

BLANKET 6

HS (18%W)

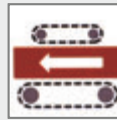
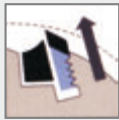
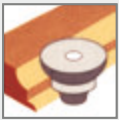
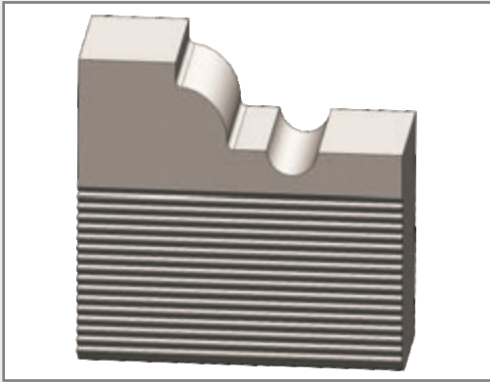

- remeselné profilové nože pre obrábanie masívu
- ustavovanie pomocou fixačného ryhovania bez prípravkov a meradiel
- ostrenie po čele a chrbte
- nasadzovanie do frézovačiek so strojným posuvom
- **ceny sú uvedené za ľubovoľný profil** nezávisle na jeho zložitosti

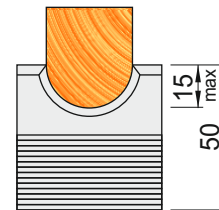

B	h	t	Nr
50	60	30	222200

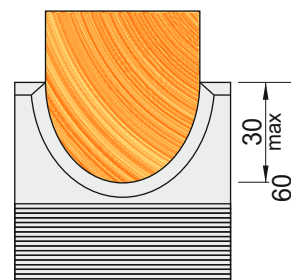
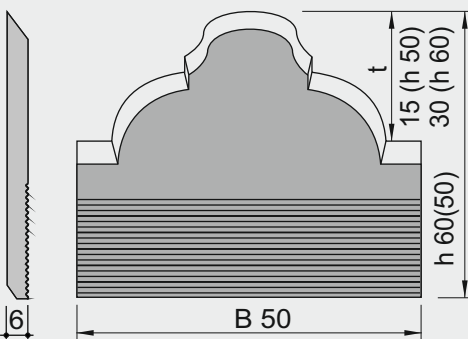

DOUBLEBACK

HW

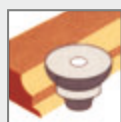
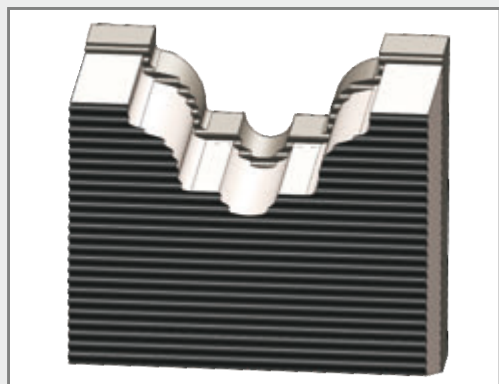

- priemyselné profilové nože pre obrábanie masívu a aglomerátov
- ustavovanie pomocou fixačného ryhovania bez prípravkov a meradiel
- ostrenie po čele a chrbte
- nasadzovanie do frézovačiek (powerlock) so strojným posuvom
- **ceny sú uvedené za ľubovoľný profil** nezávisle na jeho zložitosti

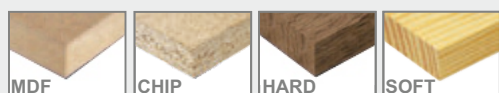
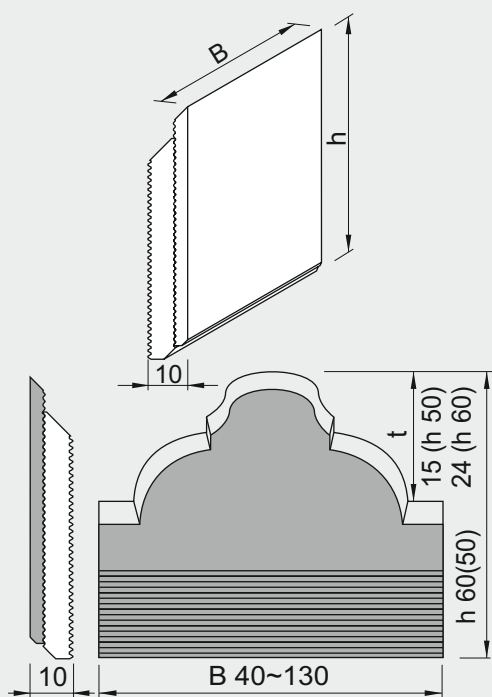

B	h	Nr
40	50	54024101
40	60	54024112
50	50	54043958
50	60	54043959
60	50	54024134
60	60	54024145
80	50	54024167
80	60	54024178
100	50	54023968
100	60	54023979
120	50	54024001
120	60	54024012
130	50	54024035
130	60	54024046

B	h	Nr
40	50	54024091
40	60	54024102
50	50	54043928
50	60	54043932
60	50	54024124
60	60	54024135
80	50	54024157
80	60	54024168
100	50	54023985
100	60	54023969
120	50	54023991
120	60	54024002
130	50	54024025
130	60	54024036

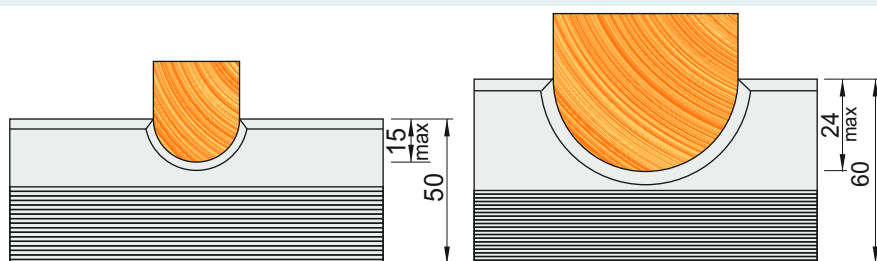

BLANKET MASIV

HW

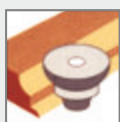
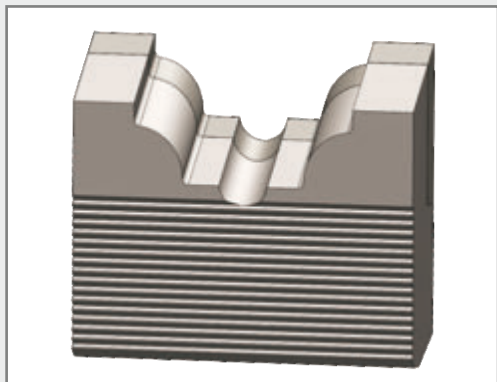

- priemyselné profilové nože pre obrábanie masívu
- ustavovanie pomocou fixačného ryhovania bez prípravkov a meradiel
- ostrenie po čele a chrbte
- nasadzovanie do frézovačiek so strojným posuvom
- **ceny sú uvedené za ľubovoľný profil** nezávisle na jeho zložitosti

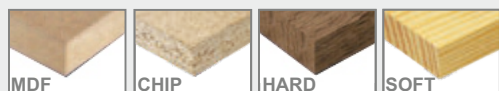
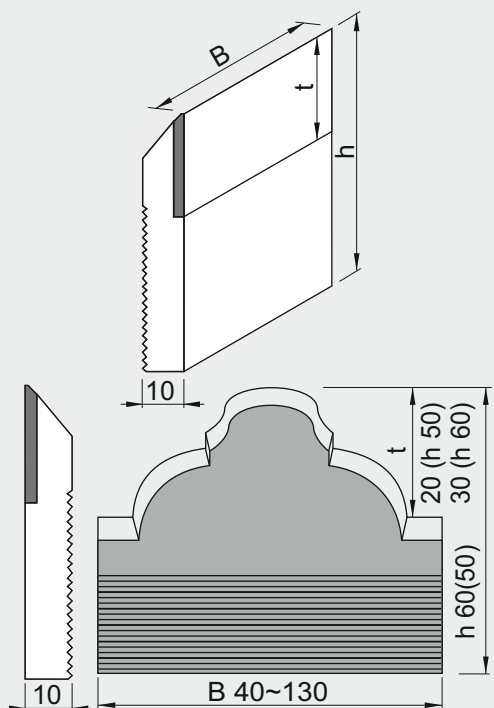

B	h	Nr
40	50	54030254
60	50	540103261
80	50	540103262
100	50	540103263
130	50	540103264

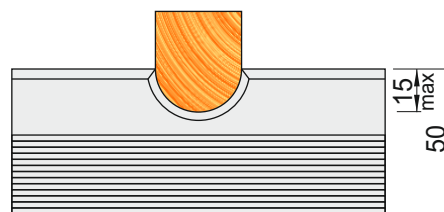

B	h	Nr
40	60	540114868
60	60	540109128
80	60	540109129
100	60	540109130
130	60	540109131

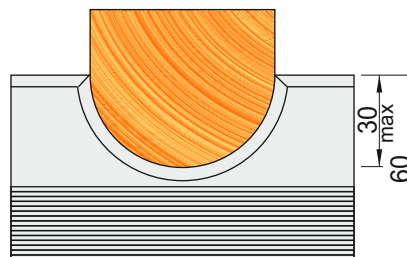

BLANKET 290

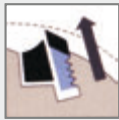
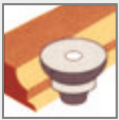
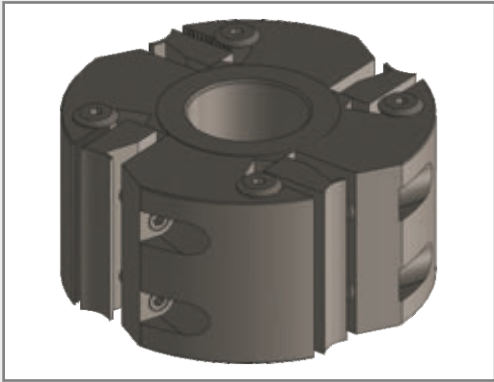

- priemyselné blanketové hlavy pre strojný posuv
- nasadzovanie do 4str. frézovačiek a spodných frézovačiek

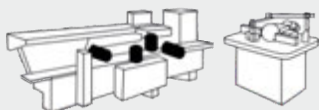
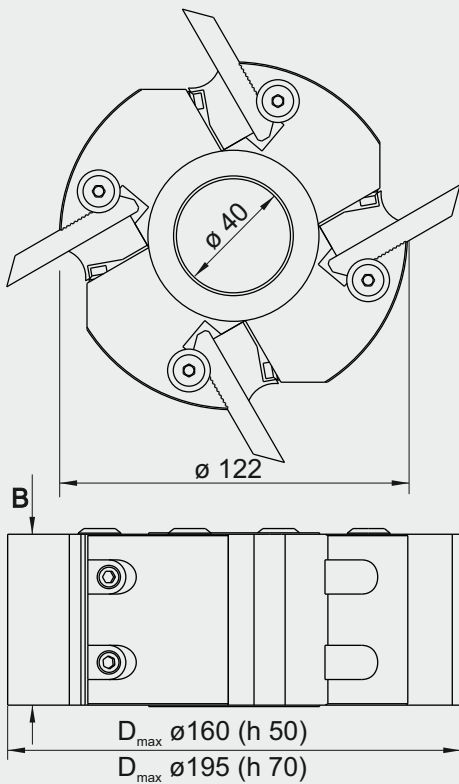

$\varnothing D$	B	Nr
122	40	290AA
122	60	290BB
122	80	290CC
122	100	290GG
122	130	290DD
122	230	290EE

Nr
 redukcia **301132**

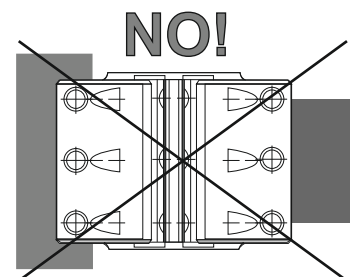
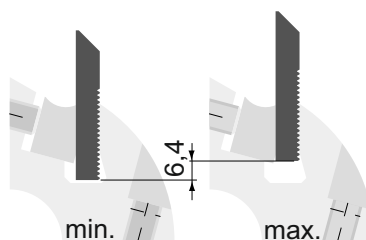
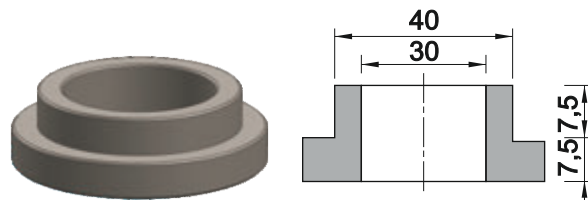

BLANKET HOBBY

ø D	B	Nr
100	50	290KK

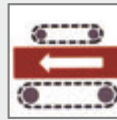
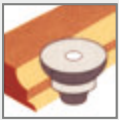
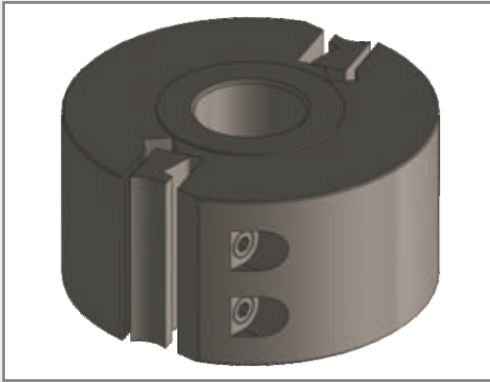

- remeselné blanketové hlavy pre strojný posuv
- nasadzovanie do spodných frézovačiek

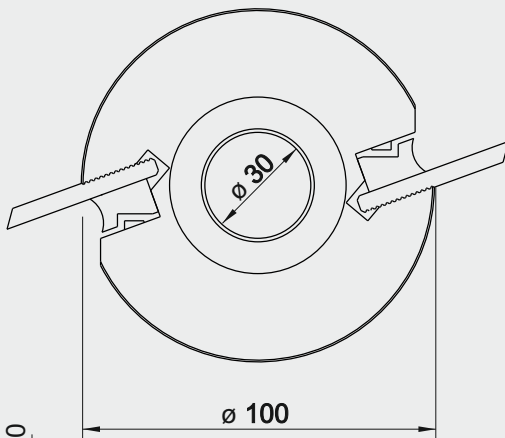

B 50

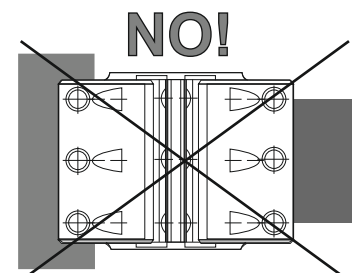
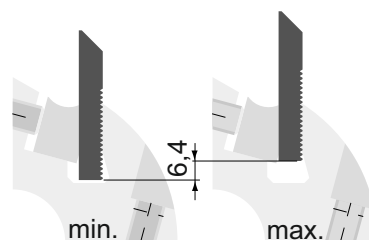
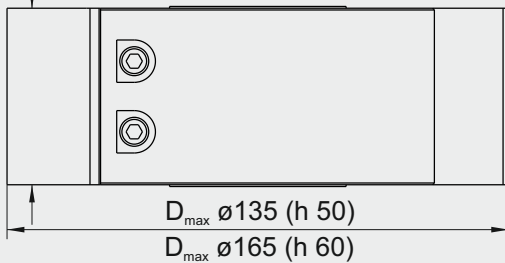

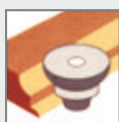
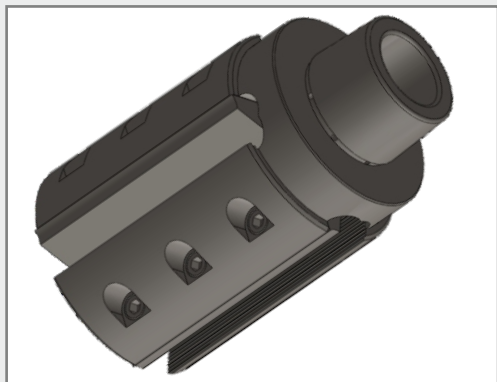

POWERLOCK

HSK 85WE

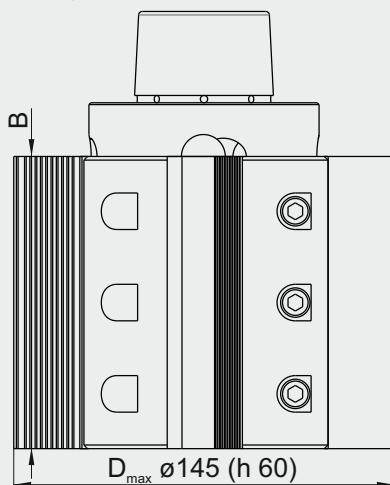
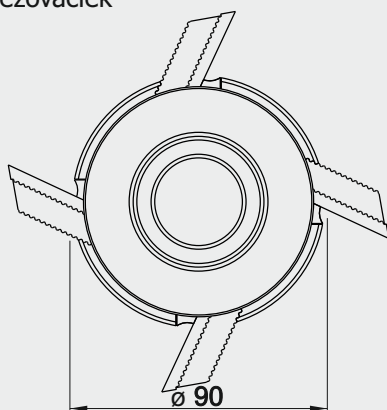

- priemyselné powerlock hlavy pre strojný posuv
- nasadzovanie do 4-štvorstranných frézovačiek



$\varnothing D$	B	Nr (Z-2) 
90	40	616260400902(R,L)
90	60	616260600902(R,L)
90	80	616260800902(R,L)
90	100	616261000902(R,L)
90	130	616261300902(R,L)
90	150	616261500902(R,L)
90	170	616261700902(R,L)
90	190	616261900902(R,L)
90	210	616262100902(R,L)
90	240	616262400902(R,L)

$\varnothing D$	B	Nr (Z-4) 
* 90	40	616260400904(R,L)
* 90	60	616260600904(R,L)
* 90	80	616260800904(R,L)
* 90	100	616261000904(R,L)
90	130	616261300904(R,L)
90	150	616261500904(R,L)
90	170	616261700904(R,L)
90	190	616261900904(R,L)
90	210	616262100904(R,L)
90	240	616262400904(R,L)

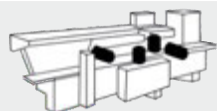

BLANKET TSP

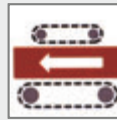
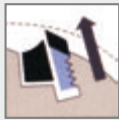
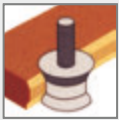
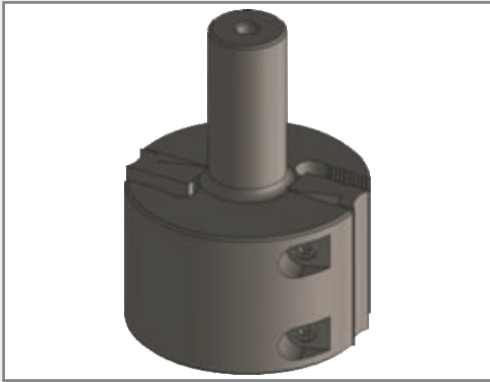

$\varnothing D$	B	$\varnothing d$	Nr
78	50	25	1117850

- priemyselné stopkové blanketové hlavy pre strojný posuv
- nasadzovanie do obrábacích centier

