

Punte elicoidali multitagliente a coltellino

Wendeplatten Spiralfräser

Mèches hélicoïdal à plaquettes réversibles

Фрезы спиральные со сменными ножами

**P940**

**HW Spiral multi-cutting router bits**

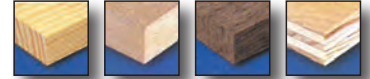

Costruite con corpo in acciaio bonificato • Coltelli con 2 lati taglienti • Indicate per la lavorazione di legni massicci teneri, medio-duri e duri • Adatte alle alte asportazioni, forniscono buona finitura • Indicate per la prima lavorazione del legno in specifico per sgrossatura e contornatura • Basso inquinamento acustico

Body in hardened and tempered steel • Turnover knives with 2 cutting edges • Suitable for working soft, medium-hard and hard wood • For high chip removal and excellent finish • Indicated for first wood working in specific for roughing and contouring • Low noise

TAGLIO / SEZIONATURA  
SAWING

DIAMANTE  
DIAMOND

FRESATURA  
CUTTING

PANTOGRAFATURA  
ROUTING

FORATURA  
BORING

MANDRINI / ATTACCHI  
CHUCKS & CLAMPING SYSTEM

RICAMBI E LAVORAZIONI SUPP.  
SPARE PARTS & ADD. WORKING

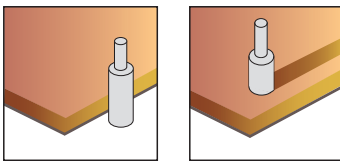
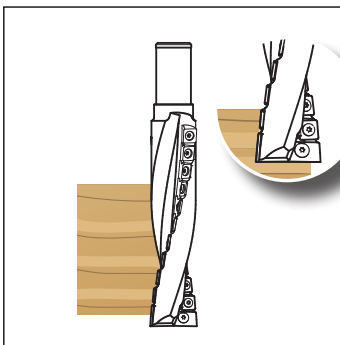
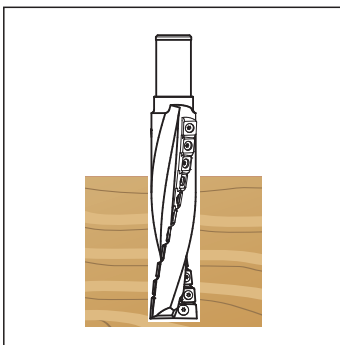
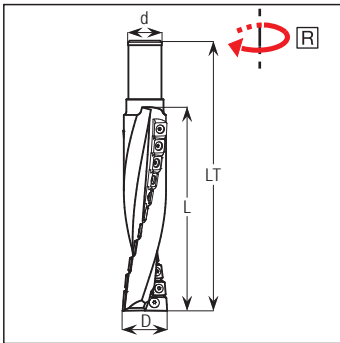

■ Utensili non a magazzino, quantità minima d'ordine: **1 pezzo**.  
Tools not ready in stock minimum order quantity: **1 piece**.

Il prezzo include una chiave di regolazione.  
The price included one screwdriver.

**Z2**

● = Ready in stock ■ = Delivery time 20 working days △ = On request

D	L	LT	d	Mod.	Z	Code
30	120	195	25/24,4	B	22+2	■ P940M30120DR
30	120	195	30/29,4	E	22+2	■ P940M30120CR
30	120	195	30	D	22+2	● P940M30120AR
40	160	235	30	D	20+2	■ P940M40160DR
40	160	235	30/29,4	E	20+2	● P940M40160CR
40	160	235	30	F	20+2	■ P940M40160AR

Spec.						P940M99
-------	--	--	--	--	--	---------

SPARE PARTS

Type	∅	Dimensions	Code
Reversible knife	30	9X9X1,5	● C020M09009AA
Screw	30	M4X4X7,5	● WV022
Plug knife	30	15X16X2	■ C940M15016AA
Plug knife	30	15X12X2	■ C940M15012AA
Reversible knife	40	12X12X1,5	● C020M12012AA
Screw	40	M4X6X7,5	● WV008
Plug knife	40	20X18,5X2	■ C940M200185A
Plug knife	40	20X12,5X2	■ C940M200125A

Esempi di attacchi/Example of shanks

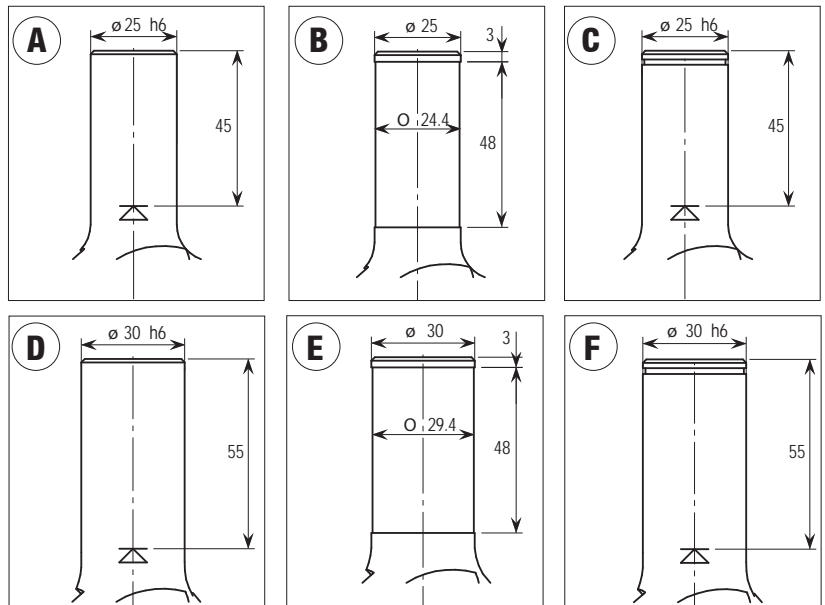

- A) Calettamento termico e hydro/ Shrink and hydro fit
- B) Ribasso di sicurezza per pinze elastiche/Safety collar for collets
- C) Ribasso di sicurezza per pinze elastiche/Safety collar for collets
- D) Calettamento termico e hydro/ Shrink and hydro fit
- E) Anello di sicurezza/Retaining ring
- F) Anello di sicurezza/Retaining ring