

Serie - Series

99-

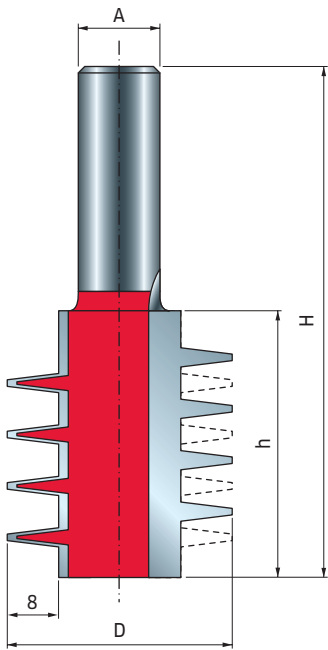

Keilzinkenfräser/Verleimfräser Finger joint bit

Schneidet alle Verbundwerkstoffe, Sperrholz, Hartholz und Weichholz. Einsatz nur an tischmontierten tragbaren Fräsmaschinen.
Zum Abtragen großer Materialmengen in mehreren Durchläufen.

Cuts all composites, plywood, hardwood and softwood. Use only on table mounted portable router machines.
Use multiple passes when removing large quantities of material.

D	h	H	A	Z	Max. Drehzahl Max RPM	Code Code	SAP SAP
35	41,5	78	12	2	16.000	99-03712P	F03FR02440

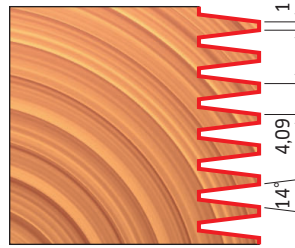

Entgegengesetzte Faserrichtung
Opposite vein direction

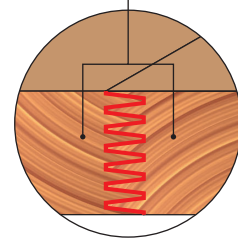

Serie - Series

99-

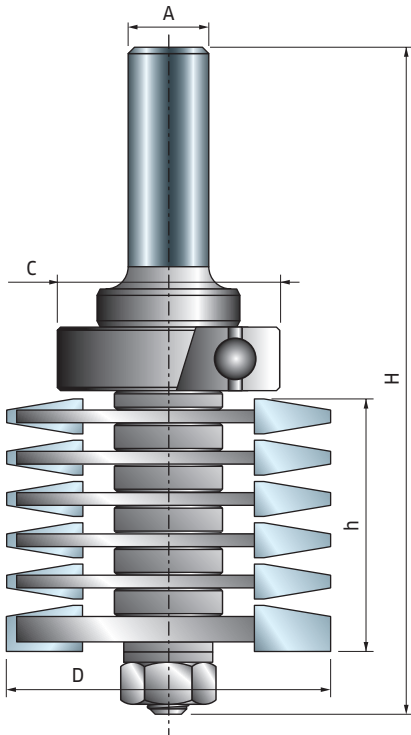

Keilzinkenfräser/Verleimfräser mit oberem Lager Top bearing finger joint bit

Schneidet alle Verbundwerkstoffe, Sperrholz, Hartholz und Weichholz. Einsatz nur an tischmontierten tragbaren Fräsmaschinen.
Zum Abtragen großer Materialmengen in mehreren Durchläufen.

Cuts all composites, plywood, hardwood and softwood. Use only on table mounted portable router machines.
Use multiple passes when removing large quantities of material.

D	h	H	A	C	Z	Max. Drehzahl Max RPM	Code Code	SAP SAP
50,8	45,2	108	12	35	2	24.000	99-03912P	F03FR02444

Ersatzteile Spare parts	Maße Dimensions mm	Code Code	SAP SAP
Sechskantmutter / Hex nut	7,94 x 6,75	2610M BB9	F03F010003
Unterlegscheibe / Ring	14 x 8,4 x 1,6	2617M BG9	F03FR01668
Kugellager / Ball bearing	35 x 15 x 11	3102M AI9	F03F012285
Distanzring / Spacer	18 x 0,1 x 8	AN01MP0019	F03FC00392
Distanzring / Spacer	18 x 1 x 8	AN01MP0109	F03FC00396
Distanzring / Spacer	18 x 2,5 x 8	AN01MP0259	F03FC00398
Distanzring / Spacer	18 x 4,4 x 8	AN01MP0449	F03FC00399

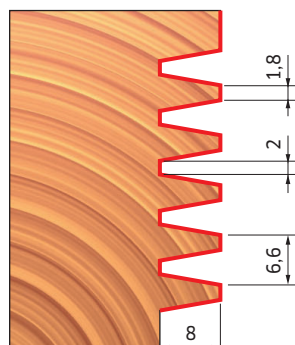

Entgegengesetzte Faserrichtung
Opposite vein direction

