

HW-Wechselplatten-Abplattfräser Panel raising cutter with TC interchangeable blades Porte-outil plate-bande à plaquettes carbure interchangeable HW

Anwendung: Zum Herstellen von Abplattungen an Türen, Möbeln und Kassetten. Zur Bearbeitung von Massivholz und Plattenwerkstoffen. Acht verschiedene HW-Profile durch das Wechselplattensystem wählbar. Durch die Höhenverstellung können bis 16 Profilvarianten erreicht werden. Für Tischfräsen mit Handvorschub geeignet.

Ausführung: Grundkörper aus hochwertiger Aluminium-Legierung, spandickenbegrenzt, rückschlagarm. Ausgerüstet mit zwei HW-Profilwechselplatten 09.1104.

Application: For production of raised panels on furniture, interior- and cabinet doors. Suitable for solid wood and wooden boards. Eight different profiles available due to TC interchangeable blade system. Horizontal adjustment of height allows up to 16 profile variations. Suitable for spindle moulders with manual feed.

Design: Tool body in light alloy with high tensile strength, chip-thickness limitation, reduced recoil, equipped with two interchangeable TC profile blades.

Emploi: Pour réaliser des plate-bande pour portes, meubles et caissons. Pour travailler le bois massif et les matières à panneaux. Possibilité de 8 profils différents grâce au système des plaquettes interchangeables HW. Le réglage des hauteurs permet de réaliser 16 variantes de profils. Adapté aux fraiseuses de table avec avance manuelle.

Construction: Corps de base en alliage léger, limité à l'épaisseur du copeau, forme anti-rejet. Équipé de 2 plaquettes interchangeables profilées HW..

Artikel-Nummer item no./num. art.	Ø D (mm)	B (mm)	d (mm)	Z	n min. - max.
11.180.025.030.A	180	25	30 – 50	2	4200 – 7000



Grundkörper Aluminium
Tool body in light alloy
Corps de base en alliage léger

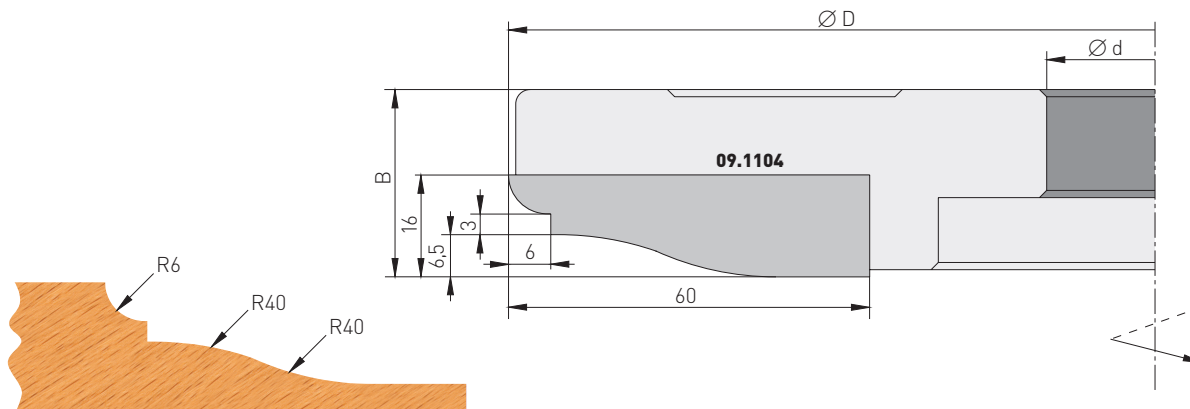

HW-Abplatt-Profilmesser / TC panel raising blade / plaquette plate-bande HW

Artikel-Nummer item no./num. art.	Beschreibung/description/description	Abmessung dimensions/dimensions	
09.1104	HW-Profilmesser / TC profile knife / plaquette profilée HW	60 x 16,0 x 2 mm	
09.1130	HW-Profilmesser / TC profile knife / plaquette profilée HW	60 x 17,5 x 2 mm	■
09.1131	HW-Profilmesser / TC profile knife / plaquette profilée HW	60 x 17,5 x 2 mm	■
09.1132	HW-Profilmesser / TC profile knife / plaquette profilée HW	60 x 17,7 x 2 mm	■
09.1133	HW-Profilmesser / TC profile knife / plaquette profilée HW	60 x 17,7 x 2 mm	■
09.1134	HW-Profilmesser / TC profile knife / plaquette profilée HW	60 x 16,0 x 2 mm	■
09.1135	HW-Profilmesser / TC profile knife / plaquette profilée HW	60 x 16,0 x 2 mm	■
09.1136	HW-Profilmesser / TC profile knife / plaquette profilée HW	60 x 16,0 x 2 mm	■

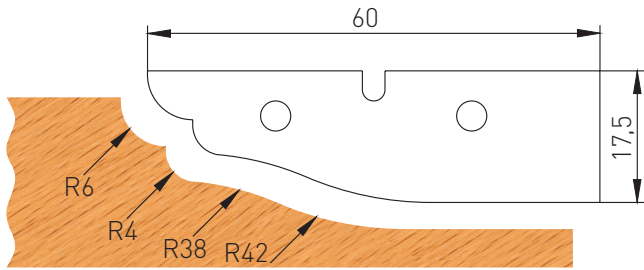

Art.-Nr./item no./num. art. (unten/below/en bas) **09.1130**

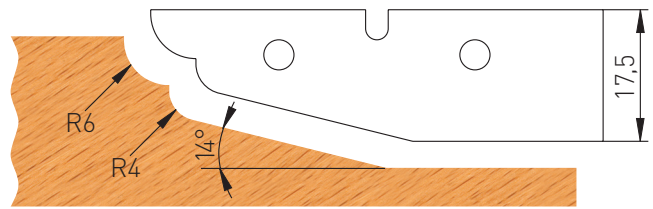

Art.-Nr./item no./num. art. (unten/below/en bas) **09.1131**

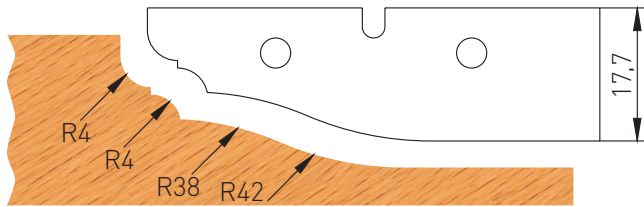

Art.-Nr./item no./num. art. (unten/below/en bas) **09.1132**

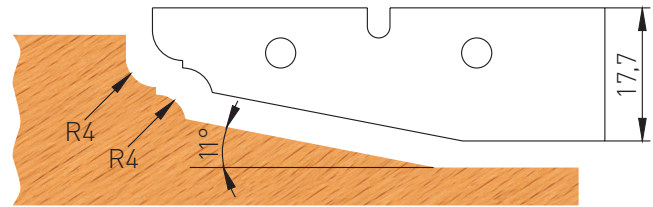

Art.-Nr./item no./num. art. (unten/below/en bas) **09.1133**

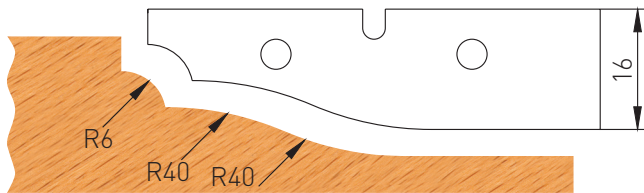

Art.-Nr./item no./num. art. (unten/below/en bas) **09.1134**

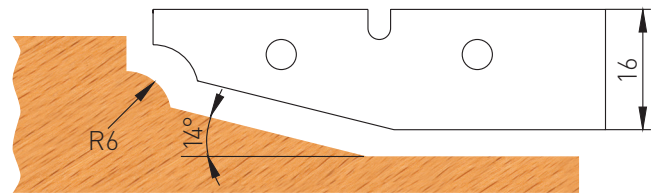

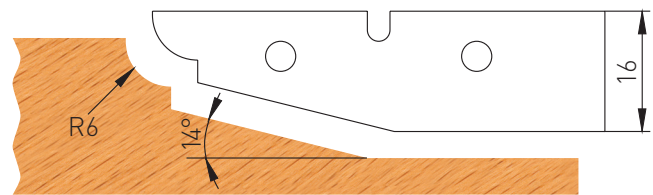

Art.-Nr./item no./num. art. (unten/below/en bas) **09.1135**



Art.-Nr./item no./num. art. (unten/below/en bas) **09.1136**

5

Ersatzteile / spare parts / pièces de rechange:

	HW-Profilmesser TC profile knife plaquette profilée HW	 Spannkeil wedge coin de serrage	 Gewindestift threaded pin goujon fileté	 Sechskant-Stiftschlüssel allen wrench clé malle à 6 pans
Art.-Nr./item no./num. art.	09.1104	09.0047	DIN 915-45H-6X16	DIN 911-ST-3
Abmessung/dimensions/dimensions	60 x 16 x 2 mm	57 x 8 x 14 mm	M 6 x 16	SW 3
Preis/price/prix €				