

V-Nutfräser "V" groove bits

Schneidet alle Verbundwerkstoffe, Sperrholz, Hartholz und Weichholz. Einsatz an CNC-Maschinen und anderen Fräsautomaten sowie handgeführten oder tischmontierten tragbaren Fräsmaschinen.
Zum Abtragen großer Materialmengen in mehreren Durchläufen.

Cuts all composites, plywood, hardwood and softwood. Use on CNC and other automatic routers as well as hand held or table mounted portable router machines.

Use multiple passes when removing large quantities of material.

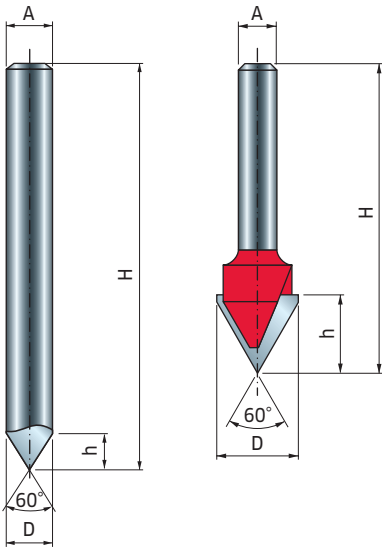

• Vollhartmetall-Fräser
Solid Carbide Bit

D	h	H	A	α	Z	Max. Drehzahl Max RPM	Code	SAP
mm	mm	mm	mm				Code	SAP
12,7	12,7	49,2	6	60°	2	24.000	20-15206P	F03FR01629
12,7	11	57,3	6	60°	3	24.000	20-15406P	F03FR01632
8	8	70	8	60°	1	24.000	20-16008P	F03FR01634
12,7	12,7	49,2	8	60°	2	24.000	20-15208P	F03FR01630
12,7	11	57,3	8	60°	3	24.000	20-15408P	F03FR01633

D	h	H	A	α	Z	Max. Drehzahl Max RPM	Code	SAP
mm	mm	mm	mm				Code	SAP
6	6	38,1	6	90°	1	24.000	20-10006P	F03FR01617
9,5	10	44,5	6	90°	2	24.000	20-10206P	F03FR01619
12,7	10	44,5	6	90°	2	24.000	20-10406P	F03FR01622
6	6	38,1	8	90°	1	24.000	20-10008P	F03FR01618
9,5	10	44,5	8	90°	2	24.000	20-10208P	F03FR01620
12,7	10	44,5	8	90°	2	24.000	20-10408P	F03FR01623
31,7	16	51	8	90°	2	18.000	20-91408P	F03FR02857
15,8	12,5	56,5	12	90°	2	24.000	20-10612P	F03FR01625
19	12,5	57,2	12	90°	2	24.000	20-10812P	F03FR01626

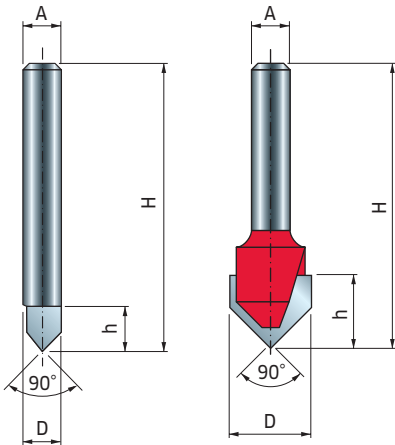

• Vollhartmetall-Fräser
Solid Carbide Bit

