

5031

TK 14559

TK 14257

5031.2

REFERENČNÍ FRÉZY
REFERENCE CUTTERS FOR PLANER ROLLS
FRÄSER FÜR HOBELKÖPFE
РЕФЕРЕНТНАЯ ФРЕЗА

5031

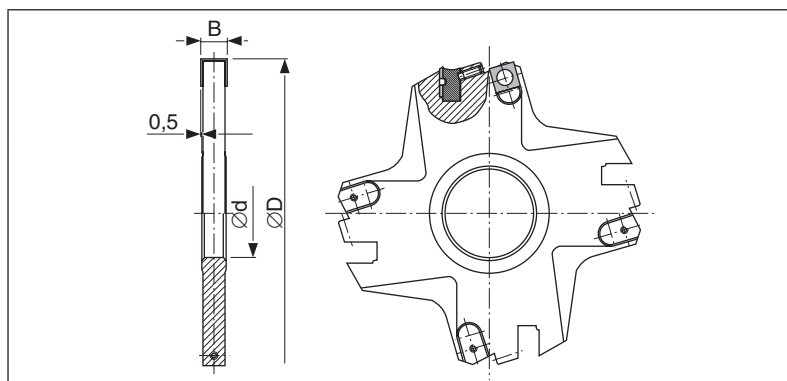
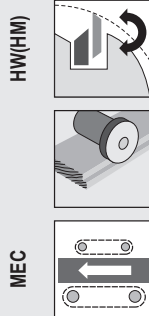

TK 14257

TK 14559

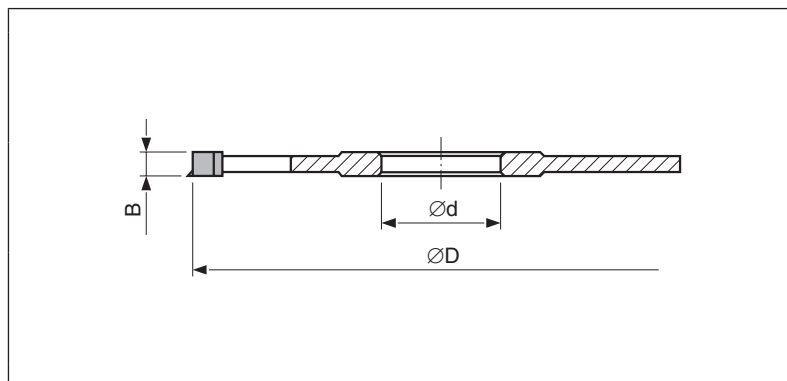
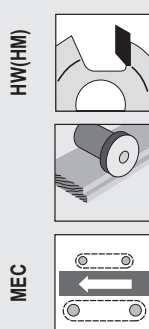
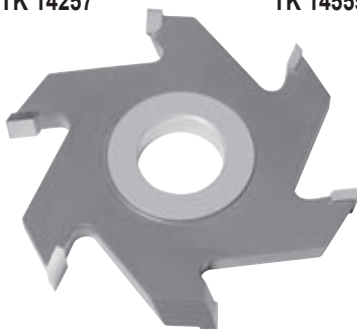

5031.2

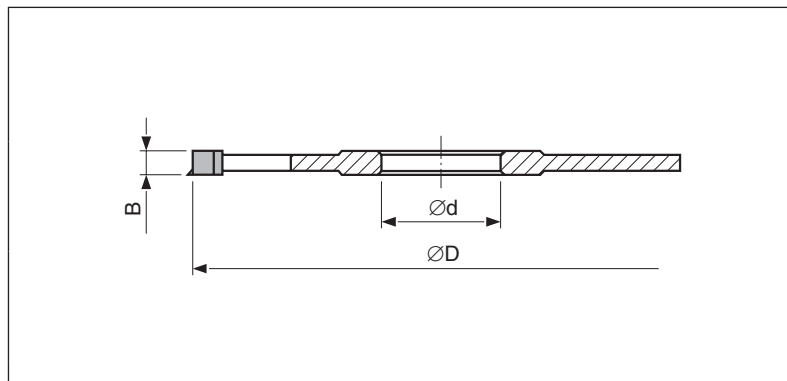
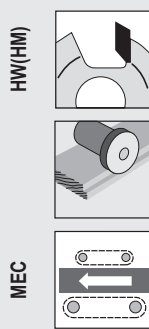

Příklady použití:

Application example:

Gebrauchsbeispiele:

Примеры использования:

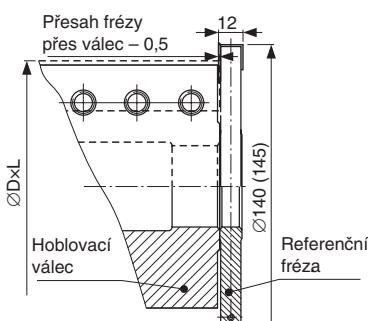

Poznámka:

Fréza se používá v kombinaci s hoblovacími válci 5132 a 5133.

Notes:

Cutter is used only in combination with planer rolls 5132, 5133.

Bemerkungen:

Anwendung der Fräse nur in Kombination mit Hobelköpfe 5132, 5133.

Примечание:

Фреза используется в комбинации со строгальными валами 5132 и 5133.

Typ	D (mm)	B (mm)	z + v	d (mm)	Typ	D (mm)	B (mm)	z + v	d (mm)
5031	140	12	4 + 4	40	Tk 14559	140	12	4 + 2	40
	145	12	4 + 4	40	Tk 14257	160	12	4 + 2	40
5031.2	145	12	2 + 2	40					

Náhradní díly – Spare Parts – Ersatzteile – Запасные части

5031					5031.2				
13260	13183	KD 81	ČSN 02 1189	TORX 20	13260	13183	KD 156	M5 x 18	TORX 25
14 x 14 x 2	11,6 x 12 x 1,5		M6 x 12	M5 x 8	14 x 14 x 2	11,6 x 12 x 1,5			M5 x 8