

Abplattfräser vertikal Vertical raised panel bits

Schneidet alle Verbundwerkstoffe, Sperrholz, Hartholz und Weichholz. Einsatz nur an tischmontierten tragbaren Fräsmaschinen.
Zum Abtragen großer Materialmengen in mehreren Durchläufen.

Cuts all composites, plywood, hardwood and softwood. Use only on table mounted portable router machines.
Use multiple passes when removing large quantities of material.

D	h	H	A	α	R	R1	R2	Z	Max. Drehzahl Max RPM	Code Code	SAP SAP
31,8	41,5	79,5	12		2	16	16	2	16.000	99-32212P	F03FR02500
31,8	41,5	79,5	12	18°				2	16.000	99-32312P	F03FR02501
31,8	41,5	79,5	12	15°	5			2	16.000	99-32412P	F03FR02502
31,8	41,5	79,5	12		38,1			2	16.000	99-32512P	F03FR02503

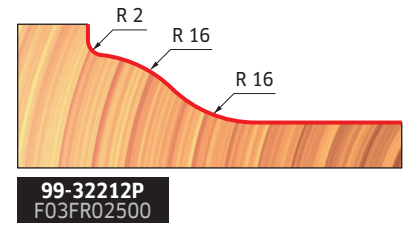
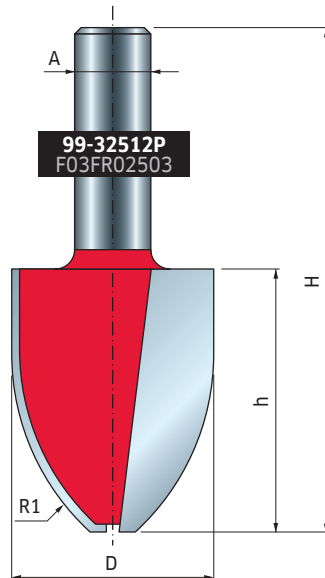
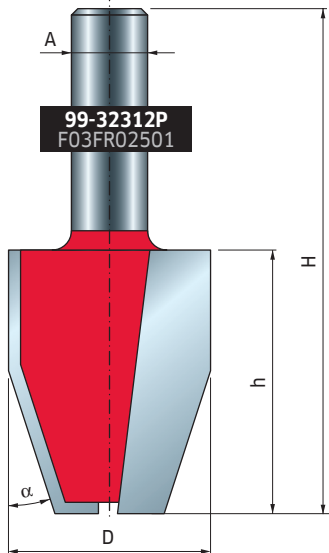
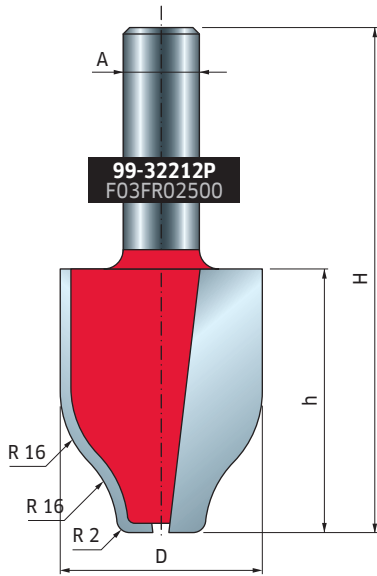

99-32212P
F03FR02500

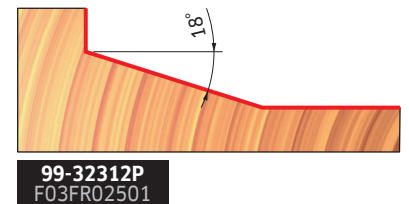

99-32312P
F03FR02501

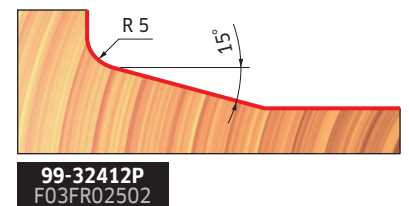

99-32412P
F03FR02502

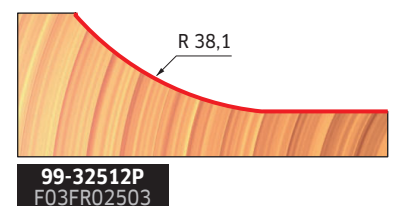

99-32512P
F03FR02503

Zum Herstellen von Abplattungen fräsen Sie die Türfüllung auf allen vier Seiten. Stellen Sie hierbei aber sicher, dass **die beiden Seiten, auf denen die Fasern quer zur Arbeitsrichtung verlaufen, zuerst gefräst werden.**

To produce the inner raised panel router the panel on all four sides but ensure that **the two across vein sides are routed first.**

