

Rundungsfräser mit oberem Lager Top bearing ogee moulding bits

Schneidet alle Verbundwerkstoffe, Sperrholz, Hartholz und Weichholz. Einsatz an CNC-Maschinen und anderen Fräsautomaten sowie handgeführten oder tischmontierten tragbaren Fräsmaschinen.
Zum Abtragen großer Materialmengen in mehreren Durchläufen.

Cuts all composites, plywood, hardwood and softwood. Use on CNC and other automatic routers as well as hand held or table mounted portable router machines.
Use multiple passes when removing large quantities of material.

D	h	H	A	C	R	Z	Max. Drehzahl Max RPM	Code	SAP
mm	mm	mm	mm	mm	mm			Code	SAP
39,5	11,5	54,6	8	19	4	2	16.000	23-10008P	F03FR01654
39,5	11,5	58	12	19	4	2	16.000	23-10012P	F03FR01655
54	11,5	58	12	19	4	2	16.000	23-10212P	F03FR01656
60,5	17,3	63,8	12	19	6,35	2	12.000	23-10412P	F03FR01657

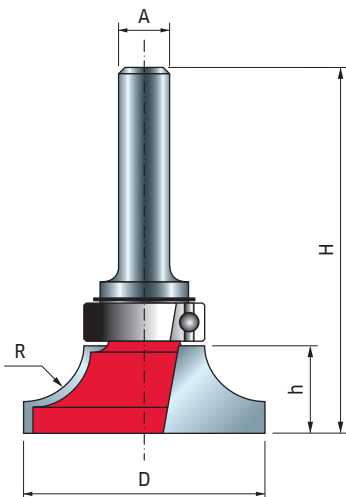
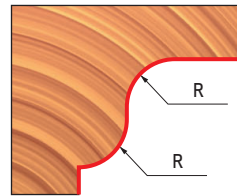

Hohlkehlfräser mit oberem Lager Top bearing cove moulding bits

Schneidet alle Verbundwerkstoffe, Sperrholz, Hartholz und Weichholz. Einsatz an CNC-Maschinen und anderen Fräsautomaten sowie handgeführten oder tischmontierten tragbaren Fräsmaschinen.
Zum Abtragen großer Materialmengen in mehreren Durchläufen.

Cuts all composites, plywood, hardwood and softwood. Use on CNC and other automatic routers as well as hand held or table mounted portable router machines.
Use multiple passes when removing large quantities of material.

D	h	H	A	C	R	Z	Max. Drehzahl Max RPM	Code	SAP
mm	mm	mm	mm	mm	mm			Code	SAP
38	12,5	55,6	8	19	6,4	2	16.000	23-20008P	F03FR01658
38	12,5	59	12	19	6,4	2	16.000	23-20012P	F03FR01659

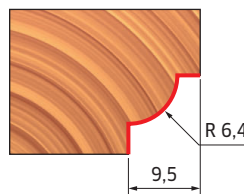

D	h	H	A	C	R	Z	Max. Drehzahl Max RPM	Code	SAP
mm	mm	mm	mm	mm	mm			Code	SAP
35	13,2	56,3	8	19	8	2	16.000	23-20208P	F03FR01660
38	14,5	57,6	8	19	9,5	2	16.000	23-20408P	F03FR01662
35	13,2	59,7	12	19	8	2	16.000	23-20212P	F03FR01661
38	14,5	61	12	19	9,5	2	16.000	23-20412P	F03FR01663

