

## T-Nutfräser T - Slotting cutter bits

Schneidet alle Verbundwerkstoffe, Sperrholz, Hartholz und Weichholz. Einsatz an handgeführten oder tischmontierten tragbaren Fräsmaschinen.

Cuts all composites, plywood, hardwood and softwood. Use on hand held or table mounted portable router machines.

D	h	H	A	Z	Max. Drehzahl Max RPM	Code	SAP
mm	mm	mm	mm			Code	SAP
28	16	59	12	2	24.000	<b>52-52012P</b>	F03FR02675
28,58	20,6	63,5	12	2	18.000	<b>52-52212P</b>	F03FR02012
30	18	61	12	2	18.000	<b>52-52612P</b>	F03FR02013

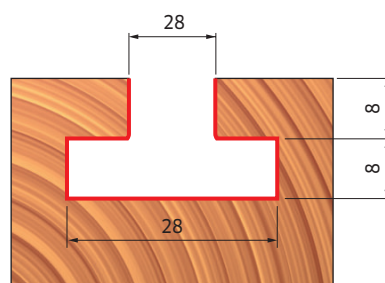
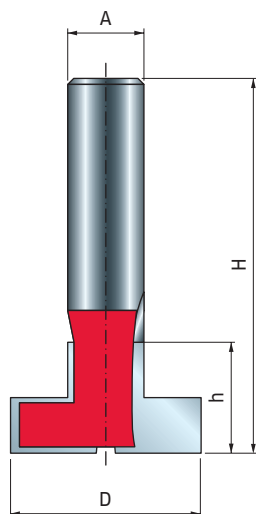

**52-52012P**  
F03FR02675

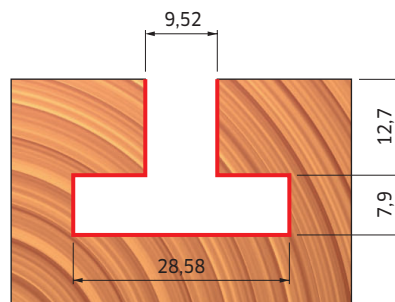

**52-52212P**  
F03FR02012

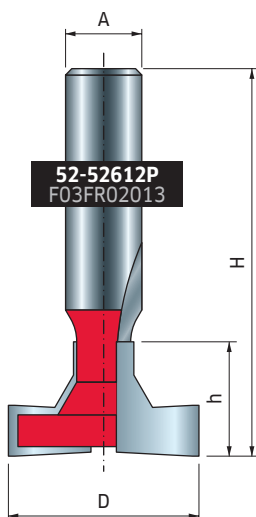

**52-52612P**  
F03FR02013

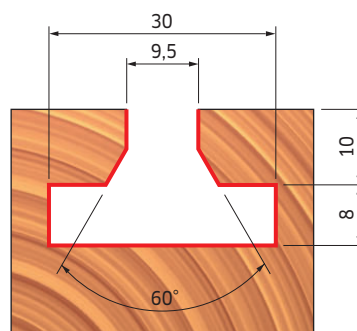

**52-52612P**  
F03FR02013