

Stirnprofilfräser Face moulding bits

Schneidet alle Verbundwerkstoffe, Sperrholz, Hartholz und Weichholz. Einsatz nur an tischmontierten tragbaren Fräsmaschinen.
Zum Abtragen großer Materialmengen in mehreren Durchläufen.

Cuts all composites, plywood, hardwood and softwood. Use only on table mounted portable router machines.
Use multiple passes when removing large quantities of material.

D	h	H	A	C	Z	Max. Drehzahl Max RPM	Code	SAP
mm	mm	mm	mm	mm			Code	SAP
31,8	20	58	12		2	24.000	99-PK212P	F03FR02408
31,8	23,8	72	12	12,7	2	18.000	99-PK312P	F03FR02409
44,4	28,6	77,1	12	12,7	2	16.000	99-00812P	F03FR02414

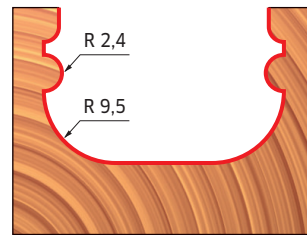
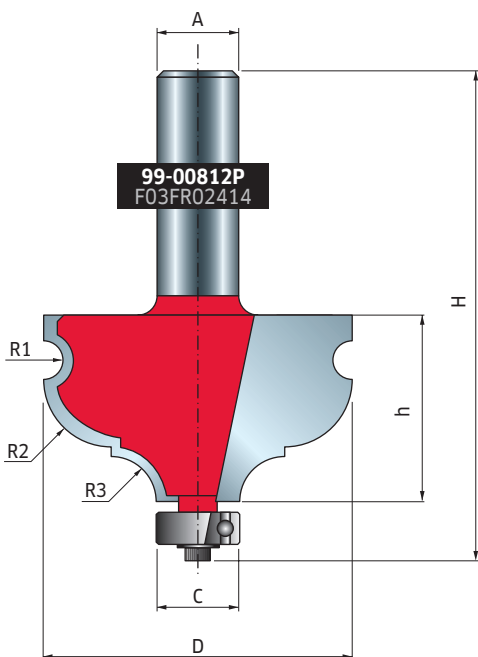
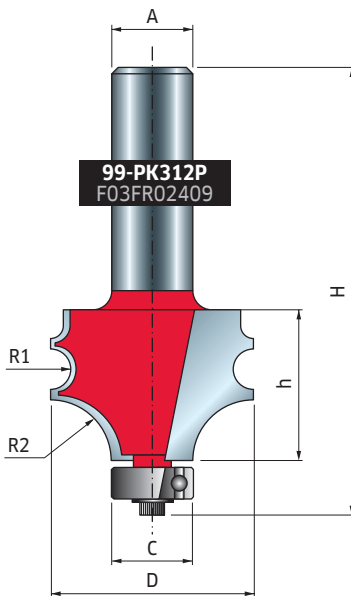
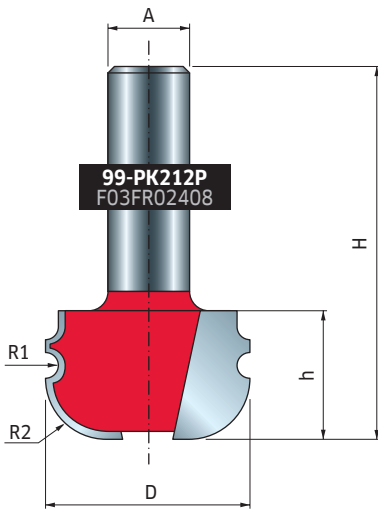

99-PK212P
F03FR02408

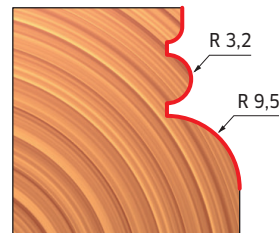

99-PK312P
F03FR02409

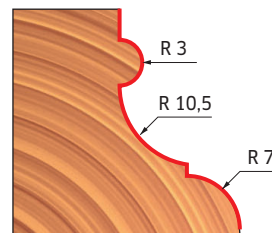

99-00812P
F03FR02414

