

5010

FRÉZY DRÁŽKOVACÍ S ROVNÝMI ZUBY  
 GROOVING CUTTERS WITH STRAIGHT TEETH  
 NUTFRÄSER MIT GERADEN SCHNEIDEN  
 ФРЕЗЫ ПАЗОВЫЕ С РОВНЫМИ ЗУБЬЯМИ

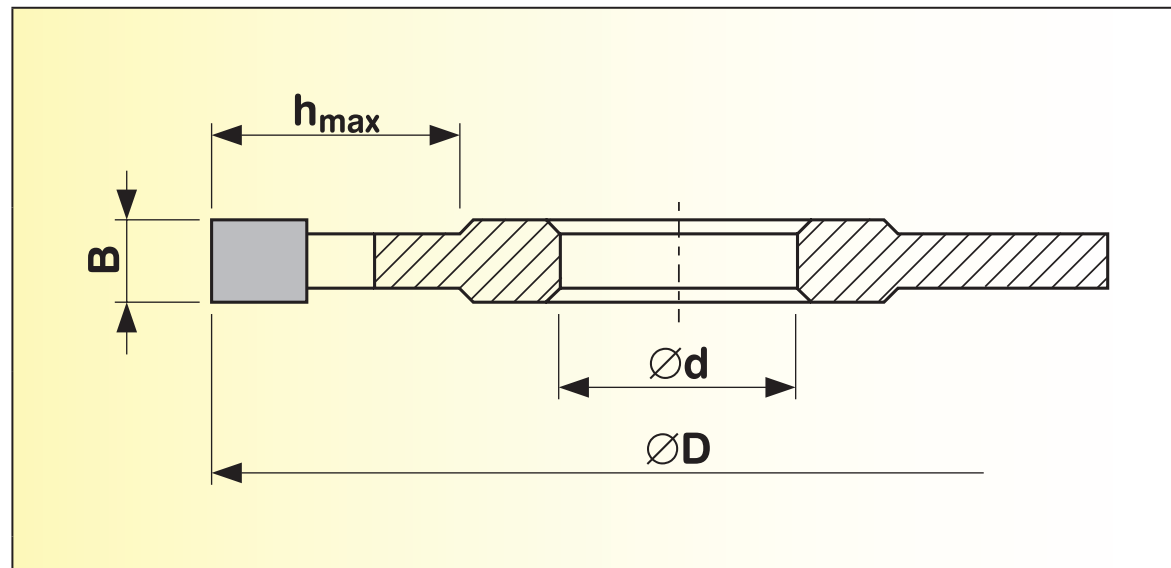
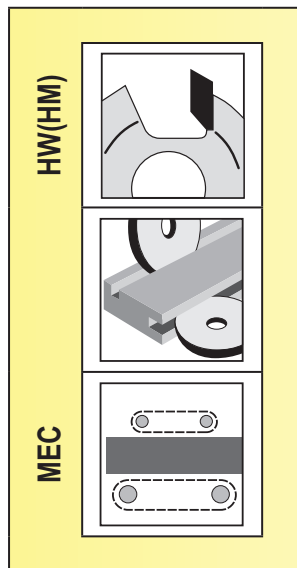
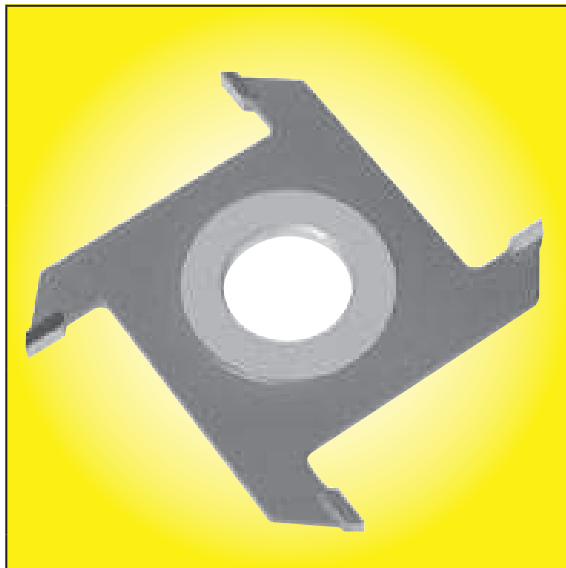

D (mm)	$n_{max}$		
125 mm	10 000 min <sup>-1</sup>		
160 mm	8 000 min <sup>-1</sup>		

D (mm)	B (mm)	$h_{max}$	z	d (mm)					
125	4	37	4	30 (40)*					
125	5	37	4	30 (40)*					
125	6	37	4	30 (40)*					
125	8	37	4	30 (40)*					
125	10	37	4	30 (40)*					
125	12	37	4	30 (40)*					
160	6	55	4	30 (40)*					
160	8	55	4	30 (40)*					
160	10	55	4	30 (40)*					
160	12	55	4	30 (40)*					

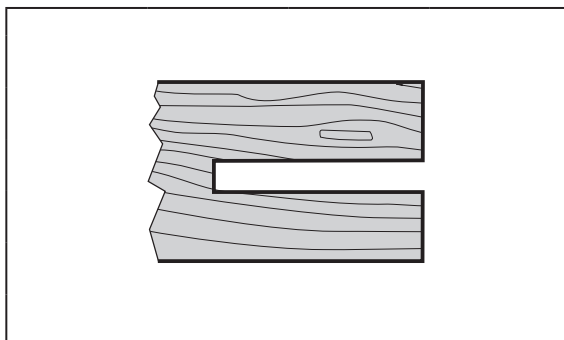

\* pouze na zvláštní požadavek \* only on special order \* nur sonderbestellung \* только под заказ