

# PI01MD

## Vollhartmetall-Gravierfräser Solid carbide engraving router cutter

Für tragbare Fräsen oder Oberfräsmaschinen.  
Ideal zum Gravieren und zum Schneiden von V-Nuten.

For portable routers or overhead machines.  
Ideal for engraving and cutting V grooves.

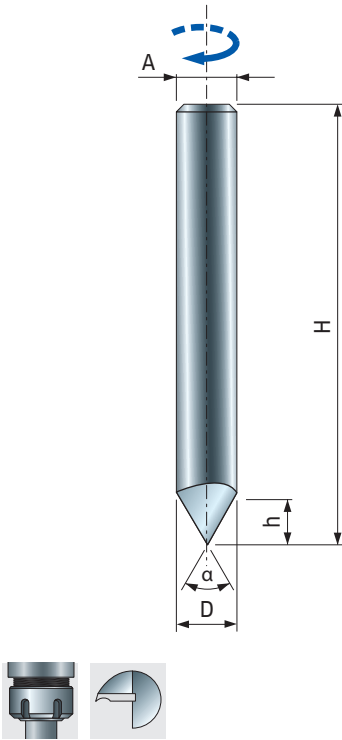

D	h	H	A	$\alpha$	Z	Max. Drehzahl Max RPM	Code	SAP
mm	mm	mm	mm				Code	SAP
8	6	70	8	60°	1	24.000	<b>PI01MD6083</b>	F03FR00382

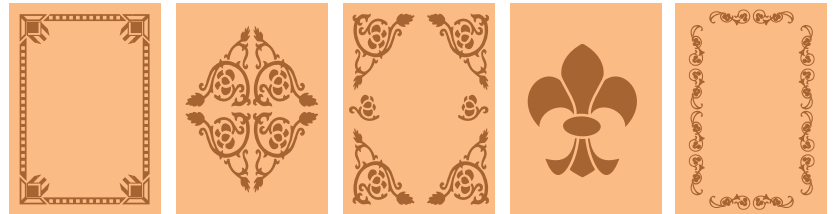

Serie - Series

# 20-

## Schriftenfräser Lettering bits

Schneidet alle Verbundwerkstoffe, Sperrholz, Hartholz und Weichholz. Einsatz an CNC-Maschinen und anderen Fräsaufautomaten sowie handgeführten oder tischmontierten tragbaren Fräsmaschinen.  
Zum Abtragen großer Materialmengen in mehreren Durchläufen.

Cuts all composition materials, plywood, hardwood and softwood. Use on CNC and other automatic routers as well as hand held or table mounted portable router machines.

Use multiple passes when removing large quantities of material.

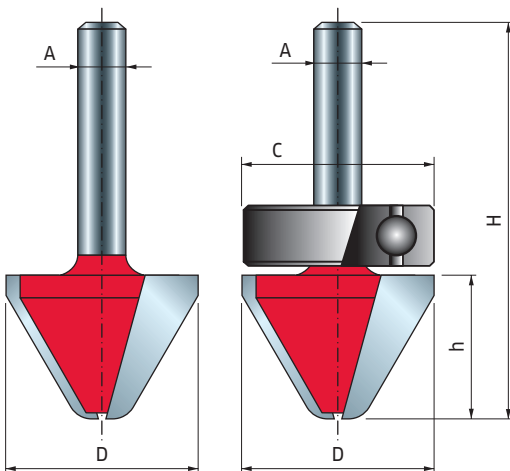

D	h	H	A	C	$\alpha$	Z	Max. Drehzahl Max RPM	Code	SAP
mm	mm	mm	mm	mm				Code	SAP
25,4	19	51	6		60°	2	24.000	<b>20-17206P</b>	F03FR01635
25,4	19	51	8		60°	2	24.000	<b>20-17208P</b>	F03FR01636
28,6	19	57	12		60°	2	18.000	<b>20-17412P</b>	F03FR01637
28,6	19	61	12	28,5	60°	2	18.000	<b>20-57412P</b>	F03FR01638

