

Serie - Series

99-

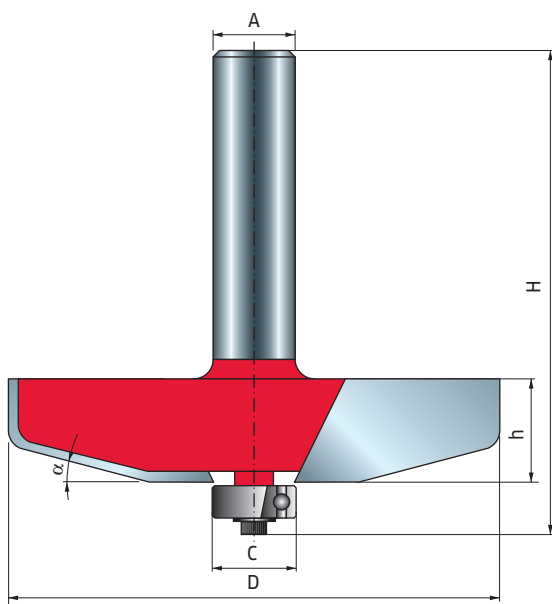

Abplattfräser Raised panel bit

Schneidet alle Verbundwerkstoffe, Sperrholz, Hartholz und Weichholz. Einsatz nur an tischmontierten tragbaren Fräsmaschinen.
Zum Abtragen großer Materialmengen in mehreren Durchläufen.

Cuts all composites, plywood, hardwood and softwood. Use only on table mounted portable router machines.
Use multiple passes when removing large quantities of material.

D	h	H	A	C	α	R	Max. Drehzahl Max RPM	Code Code	SAP SAP
76,2	16	64,7	12	12,7	15°	4,8	12.000	99-22412P	F03FR02461

Ersatzteile Spare parts	Maße Dimensions mm	Code Code	SAP SAP
Schraube / Screw	M3 x 7,6	2607M 001	F03F010000
Kugellager / Ball bearing	12,7x4,98x4,76	3102M AB9	F03F010007
Unterlegscheibe / Washer	12 x 1,1 x 4,8	FX07M AB9	F03F010159

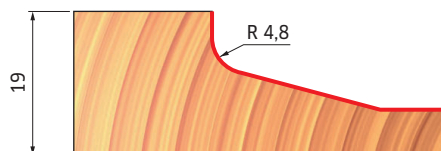

Serie - Series

99-

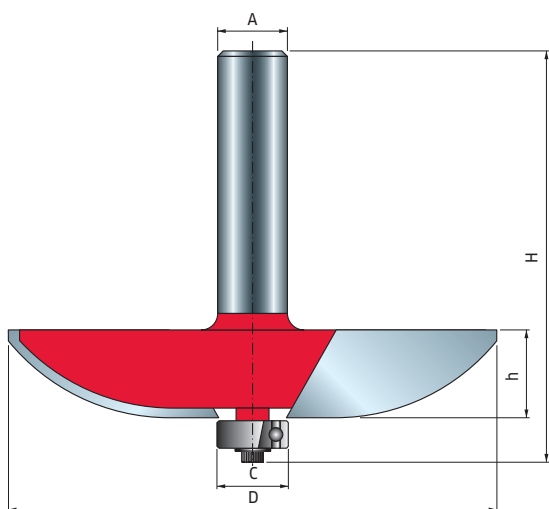

Abplattfräser Raised panel bit

Schneidet alle Verbundwerkstoffe, Sperrholz, Hartholz und Weichholz. Einsatz nur an tischmontierten tragbaren Fräsmaschinen.
Zum Abtragen großer Materialmengen in mehreren Durchläufen.

Cuts all composites, plywood, hardwood and softwood. Use only on table mounted portable router machines.
Use multiple passes when removing large quantities of material.

D	h	H	A	C	R	Z	Max. Drehzahl Max RPM	Code Code	SAP SAP
89	16	64,7	12	12,7	38,1	2	10.000	99-22512P	F03FR02462

Ersatzteile Spare parts	Maße Dimensions mm	Code Code	SAP SAP
Schraube / Screw	M3 x 7,6	2607M 001	F03F010000
Kugellager / Ball bearing	12,7x4,98x4,76	3102M AB9	F03F010007
Unterlegscheibe / Washer	12 x 1,1 x 4,8	FX07M AB9	F03F010159

