

Eintauch-Viertelstabfräser klassisch Classical beading groove bits

Schneidet alle Verbundwerkstoffe, Sperrholz, Hartholz und Weichholz. Einsatz an CNC-Maschinen und anderen Fräsautomaten sowie handgeführten oder tischmontierten tragbaren Fräsmaschinen.
Zum Abtragen großer Materialmengen in mehreren Durchläufen.

Cuts all composites, plywood, hardwood and softwood. Use on CNC and other automatic routers as well as hand held or table mounted portable router machines.
Use multiple passes when removing large quantities of material.

D	h	H	A	R	Z	Max. Drehzahl Max RPM	Code Code	SAP SAP
mm	mm	mm	mm	mm				
12,7	9,5	41,5	6	1,2	2	24.000	39-30206P	F03FR01878
15,8	9,5	41,5	6	2,4	2	24.000	39-30406P	F03FR01881
22,2	12	44	6	3,2	2	24.000	39-30606P	F03FR01884
12,7	9,5	41,5	8	1,2	2	24.000	39-30208P	F03FR01879
15,8	9,5	41,5	8	2,4	2	24.000	39-30408P	F03FR01882
22,2	12	44	8	3,2	2	24.000	39-30608P	F03FR01885

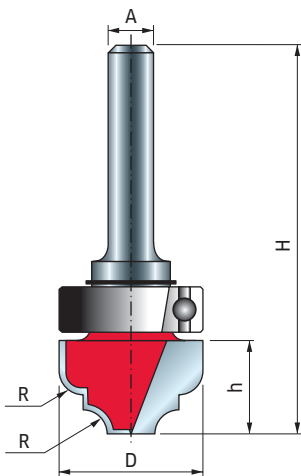
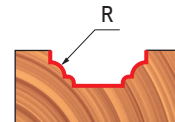

Profilfräser mit oberem Lager Top bearing cove & bead groove bits

Schneidet alle Verbundwerkstoffe, Sperrholz, Hartholz und Weichholz. Einsatz an handgeführten oder tischmontierten tragbaren Fräsmaschinen.
Zum Abtragen großer Materialmengen in mehreren Durchläufen.

Cuts all composites, plywood, hardwood and softwood. Use on hand held or table mounted portable router machines.
Use multiple passes when removing large quantities of material.

D	h	H	A	C	R	Z	Max. Drehzahl Max RPM	Code Code	SAP SAP
mm	mm	mm	mm	mm	mm				
19	12,5	55	6	19	3,2	2	24.000	39-53206P	F03FR01892
28	14	56,8	8	28	4	2	18.000	39-53808P	F03FR01894
28	14	64,1	12	28	4	2	18.000	39-53812P	F03FR01895

