

## 30185

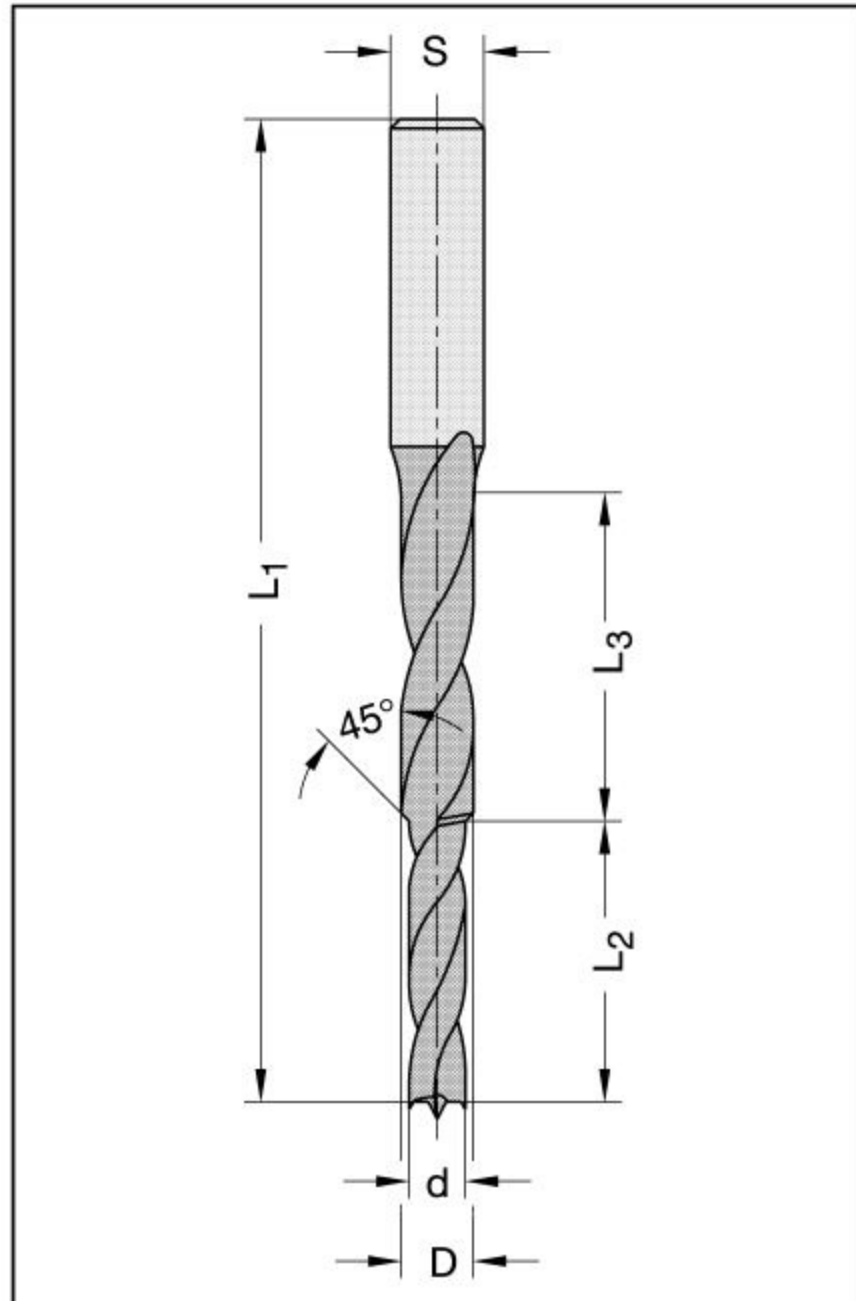

Hinge size	D mm	d mm	L <sub>2</sub> mm	L <sub>3</sub> mm	L <sub>1</sub> mm	Shank mm	Part-No.
14,5	7,2	6,3	24	40	105	10 x 30	30185-4-07201-R ●
16	7,7	6,7	30	35	105	10 x 30	30185-4-07701-R ●
18	8,7	7,7	30	35	105	10 x 30	30185-4-08701-R ◆
20	9,8	8,8	30	35	105	10 x 30	30185-4-09801-R ◆
-	6,8	6,0	15	50	105	10 x 30	30185-4-06801-R ◆

T.C.-tipped design as well as other dimensions on inquiry.

### Technical details:

Front drill with centre point and spurs. Counter sunk 45°. Parallel shank 10 x 30 mm without driving flat. Right-hand rotation.

### Application:

For stepped drill holes to screw in spigot hinges e.g. Anuba, Simons etc. Application with boring jigs and devices as well as on CNC machines.