

BLANKET HOBBY

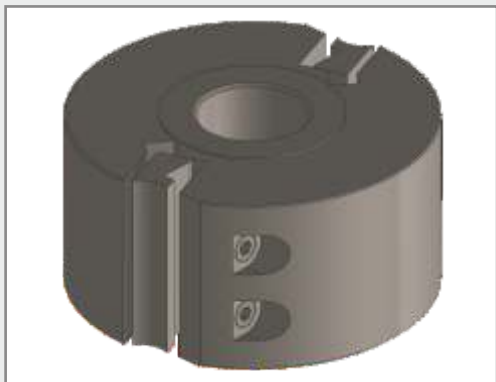

ø D	B	Nr
100	50	290KK

- remeselné blanketové hlavy pre strojný posuv
- nasadzovanie do spodných frézovačiek

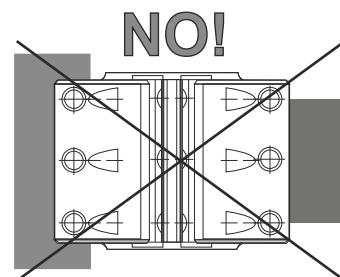
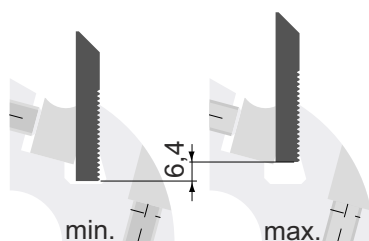
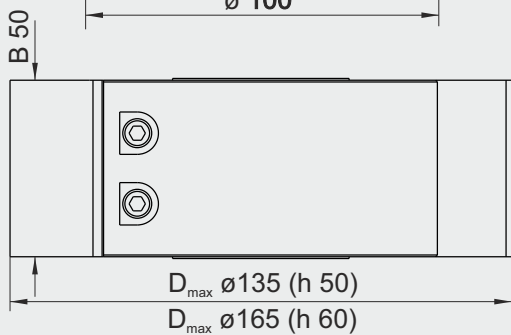
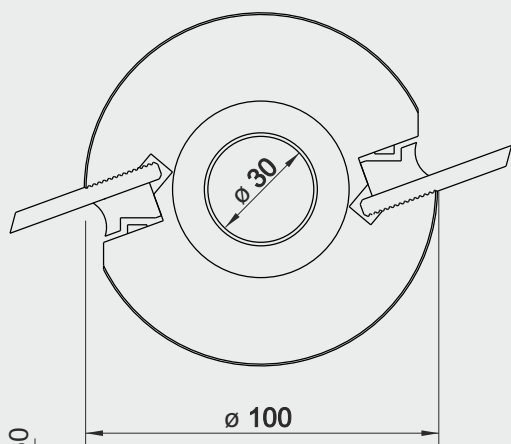

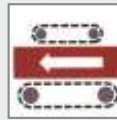
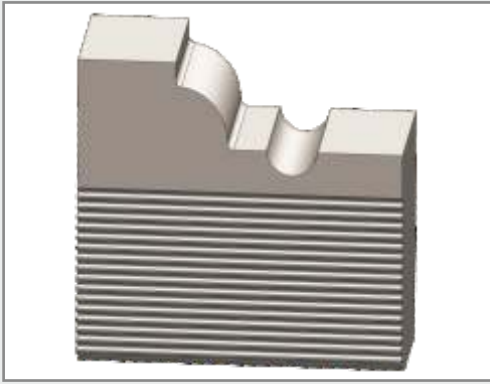

- remeselné profilové nože pre obrábanie masívu
- ustavovanie pomocou fixačného ryhovania bez prípravkov a meradiel
- ostrenie po čele a chrbte
- nasadzovanie do frézovačiek so strojným posuvom
- **ceny sú uvedené za ľubovoľný profil** nezávisle na jeho zložitosti

BLANKET 6 HS (18%W)

B	h	t	Nr
50	50	15	222201

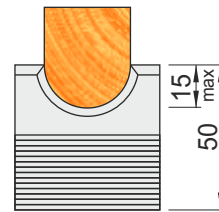

B	h	t	Nr
50	60	30	222200

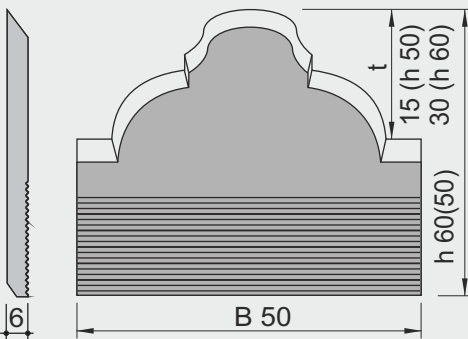
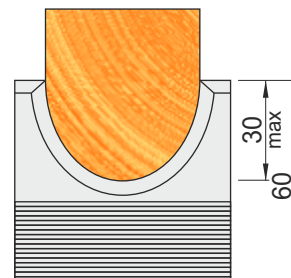

výroba profilového noža do 48 hod.