

## Halbrundfräser Round nose bits

Schneidet alle Verbundwerkstoffe, Sperrholz, Hartholz und Weichholz. Einsatz an CNC-Maschinen und anderen Fräsautomaten sowie handgeführten oder tischmontierten tragbaren Fräsmaschinen.

Zum Abtragen großer Materialmengen in mehreren Durchläufen.

Cuts all composites, plywood, hardwood and softwood. Use on CNC and other automatic routers as well as hand held or table mounted portable router machines.

Use multiple passes when removing large quantities of material.

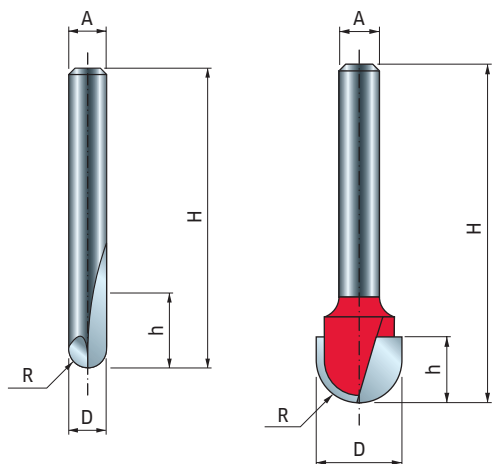

- Vollhartmetall-Fräser  
Solid Carbide Bit

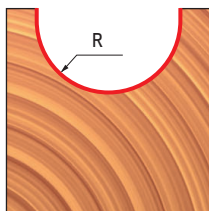

D	h	H	A	R	Z	Max. Drehzahl Max RPM	Code Code	SAP SAP
3,2	9,5	50,5	6	1,6	2	24.000	<b>18-10006P</b>	F03FR01581
4,8	9,5	50,5	6	2,4	2	24.000	<b>18-10206P</b>	F03FR01584
6	12,7	50,8	6	3	2	24.000	<b>18-10406P</b>	F03FR01587
9,5	9	46	6	4,8	2	24.000	<b>18-10606P</b>	F03FR01590
12	9	46	6	6	2	24.000	<b>18-10806P</b>	F03FR01593
15,8	11	50,8	6	8	2	24.000	<b>18-11006P</b>	F03FR01596
19	11	50,8	6	9,5	2	24.000	<b>18-11206P</b>	F03FR01599
3,2	9,5	50,5	8	1,6	2	24.000	<b>18-10008P</b>	F03FR01582
4,8	9,5	50,5	8	2,4	2	24.000	<b>18-10208P</b>	F03FR01585
6	12,7	50,8	8	3	2	24.000	<b>18-10408P</b>	F03FR01588
9,5	9	46	8	4,8	2	24.000	<b>18-10608P</b>	F03FR01591
12	9	46	8	6	2	24.000	<b>18-10808P</b>	F03FR01594
15,8	11	50,8	8	8	2	24.000	<b>18-11008P</b>	F03FR01597
19	11	50,8	8	9,5	2	24.000	<b>18-11208P</b>	F03FR01600
6	9,5	57	12	3	2	24.000	<b>18-11412P</b>	F03FR01602
12,7	31,7	71,5	12	6,35	2	24.000	<b>18-11612P</b>	F03FR01604
19	31,7	73	12	9,5	2	24.000	<b>18-12212P</b>	F03FR01606
25,4	31,7	73	12	12,7	2	24.000	<b>18-12612P</b>	F03FR01608

### FRÄSER MIT KUGELLAGER - BITS WITH BALL BEARING

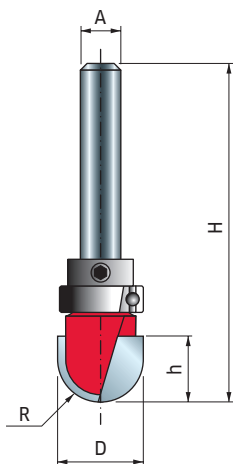

D	h	H	A	C	R	Z	Max. Drehzahl Max RPM	Code Code	SAP SAP
15,8	11	59,5	6	15,8	8	2	24.000	<b>18-51006P</b>	F03FR01609
19	11,1	59,5	6	19	9,5	2	24.000	<b>18-51206P</b>	F03FR01611
15,8	11	59,5	8	15,8	8	2	24.000	<b>18-51008P</b>	F03FR01610
19	11,1	59,5	8	19	9,5	2	24.000	<b>18-51208P</b>	F03FR01612

