

# TP42M

## TESTA PORTACOLTELLI MULTIPROFILI PER PORTE MULTIPROFILE CUTTERHEAD FOR DOORS

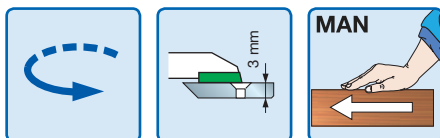

**COLTELLI RIAFFILABILI**  
**RESHARPENABLE KNIVES**



- > UTENSILI COLLAUDATI SECONDO LA NORMATIVA
- > TOOLS TESTED ACCORDING TO THE NORM

• EN 847-1 •

**R&S - SV/R 169/168**

### > CARATTERISTICHE:

Questo utensile è stato progettato per essere utilizzato su macchine toupie. Particolarmente indicato per la profilatura di legni teneri, duri ed esotici, con ottima finitura. La versatilità di questo utensile permette di produrre porte con spessori da 44 a 52 mm. Questo può essere ottenuto con due passate, capovolgendo la parte già lavorata per la seconda lavorazione ed avendo l'accortezza di regolare l'altezza di programmazione dell'utensile. I coltelli, di diverso profilo, sono perfettamente intercambiabili tra loro e mantengono il diametro minimo di lavorazione.

### > FEATURES:

This tool is designed to be used on moulding. Mostly suitable for moulding and profiling on soft, hard and exotic wood, with a top quality finish. The tool's versatility allows you to produce 44 - 52 mm thick doors. This can be achieved with two passes and by capsiding the machined part for the second run, taking care to adjust the tool's programmed height accordingly. The variously profiled knives are perfectly interchangeable and do not affect the minimum tool diameter.

D mm	B mm	d* mm	Z	R	CODICE CODE
176	40	35 (50)	2	4	TP42M AB3

PARTI DI RICAMBIO SPARE PARTS	DIMENSIONI DIMENSIONS	CODICE CODE
Vite / Screw	M5 x 7 x 16	VT08M AE9
Cuneo / Wedge	21 x 19 x 8	CN13M AS9
Vite / Screw	M10 x 18	VT03M CC9
Inserto rasante / Spur insert	40 x 4 x 7	IG05MD AA3
Vite / Screw	M6 x 14,5	VT16M AA9
Inserto per incastri Grooving insert	34 x 8 x 16	SR06M AM3
Vite / Screw	M6 x 11,5	VT16M AB9
Chiave / Allen key	4 x 110	CB03M BA9
Chiave / Allen key	5 x 110	CB03M EA9

> Corpo in lega leggera (ERGAL). Per la pulizia non utilizzare prodotti contenenti soda caustica.  
**L'ARTICOLO VIENE FORNITO SENZA COLTELLI.**

> Light alloy body (ERGAL). For cleaning do not use products containing caustic soda.  
**THIS ITEM IS SUPPLIED WITHOUT KNIVES.**

COLTELLI DI RICAMBIO SPARE KNIVES	DIMENSIONI DIMENSIONS	CODICE CODE
1 Coltello / Knife	24 x 34 x 3	CP42M AA3
2 Coltello / Knife	24 x 34 x 3	CP42M BA3
3 Coltello / Knife	24 x 34 x 3	CP42M CA3
4 Coltello / Knife	24 x 34 x 3	CP42M DA3
5 Coltello / Knife	24 x 34 x 3	CP42M EA3

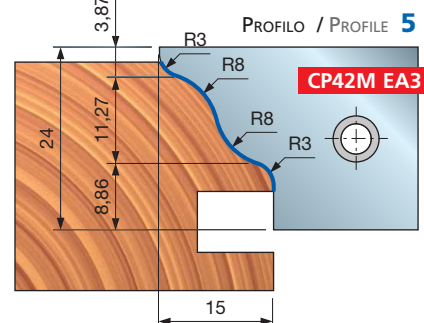
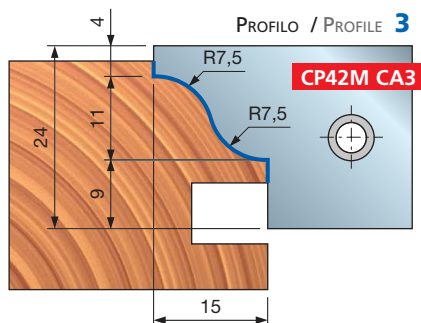
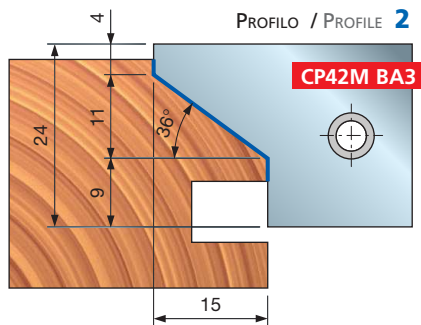
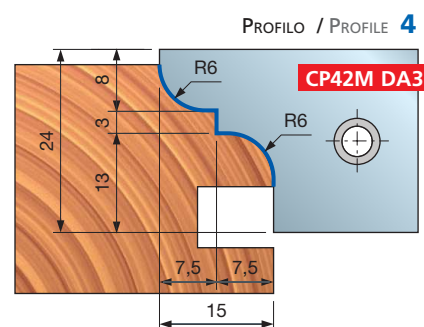
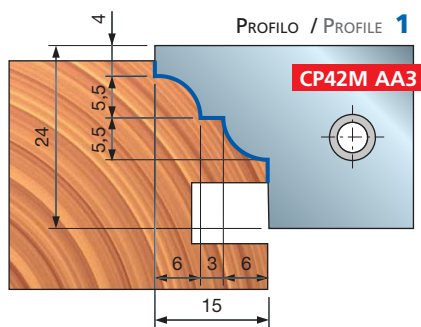

▲ I profili 4 e 5 sono utilizzabili solamente con avanzamento meccanico.  
Profiles 4 and 5 are usable with automatic feed only.  
▼

# ESECUZIONE DEL CONTROPROFILO CON SPINA

## DOOR TENONING

1

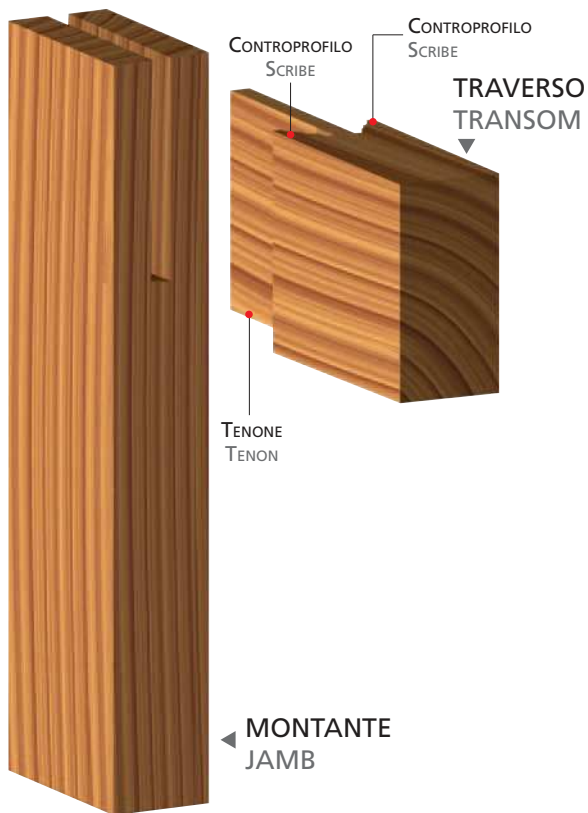

A	SPESORE PORTA DOOR THICKNESS	B	SPESORE TENONE TENON THICKNESS
	44 mm		8 mm
	46 mm		10 mm
	50 mm		14 mm
	52 mm		16 mm

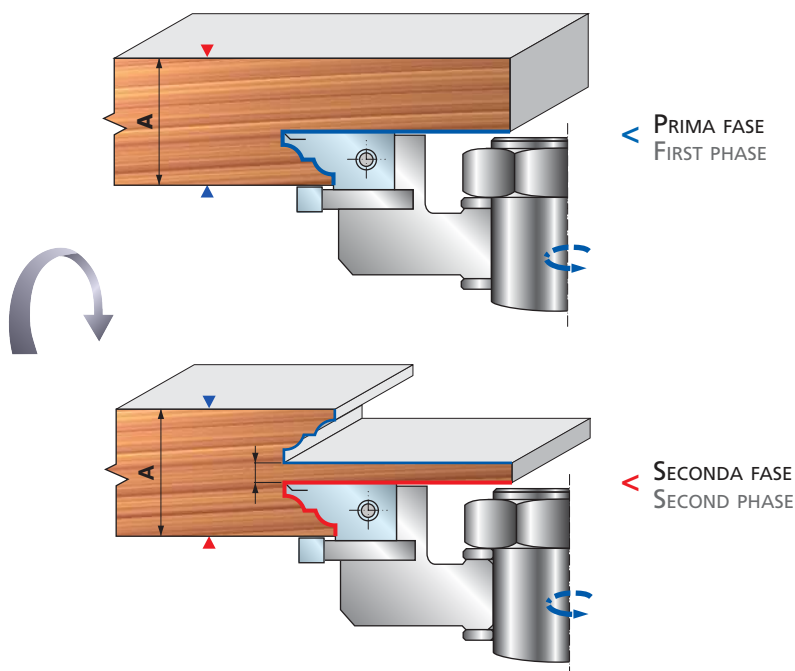

2

# PROFILATURA DEI MONTANTI E DEI TRAVERSI

## DOOR FRAME PROFILING

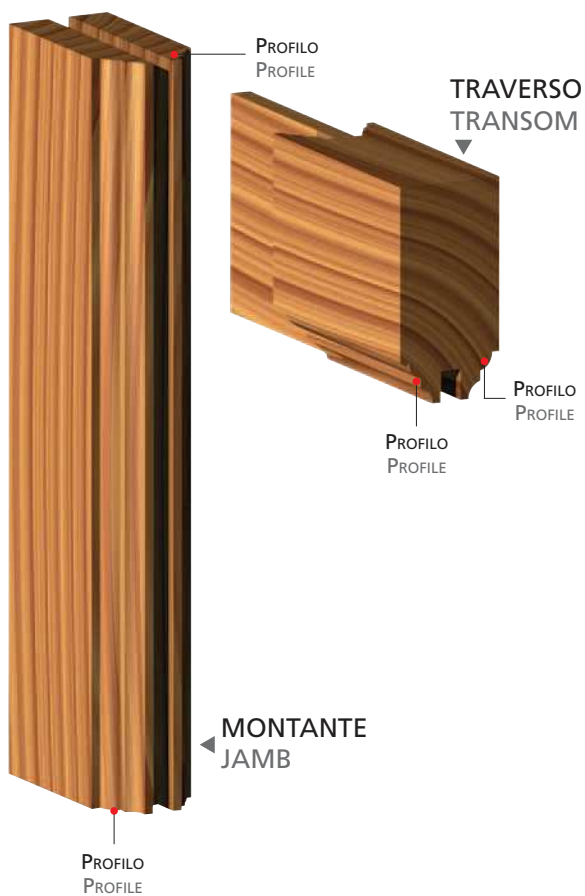

A	SPESORE PORTA DOOR THICKNESS	C	SPESORE INCASTRO GROOVE THICKNESS
	44 mm		8 mm
	46 mm		10 mm
	50 mm		14 mm
	52 mm		16 mm

