

HW-Wechselplatten-Multiprofilfräser Multi profile cutter with TC interchangeable blades Porte-outil multi profils à plaquettes carbure interchangeables HW

Anwendung: Zum Herstellen von Profil- oder Glasleisten, Kantenprofile, Vertäfelungsprofile oder Deckleisten in Hart- oder Weichholz.

Ausführung: Grundkörper aus hochwertiger Aluminium-Legierung, mit zwei HW-Profilmesser ausgerüstet, formschlüssig, spandickenbegrenzt und rückschlagarm. Für Tischfräsen mit Handvorschub geeignet.

Application: For profiled battens, glass strips, edge profiles and raised panels in soft and hard wood. Suitable for spindle moulders with manual feed.

Design: Tool body in light alloy with high tensile strength, chip-thickness limitation, reduced recoil and low noise, equipped with two TC profile reversible blades.

Emploi: Pour réaliser des lattes profilées ou bordure de verre, les bords profilés, les profils de lambrissage, les baguettes de recouvrement en bois dur ou tendre. Adapté aux fraiseuses de table avec avance manuelle.

Construction: Corps de base en alliage léger, équipé de 2 plaquettes profilées HW, forme anti-rejet, limité à l'épaisseur du copeau.

Artikel-Nummer item no./num. art.	Ø D (mm)	B (mm)	d (mm)		Z	n min. - max.	
14.120.040.030.A	120	40	30 - 40		2	6400 - 10000	■
14.160.050.030.A	160	50	30 - 50		2	4800 - 8300	■

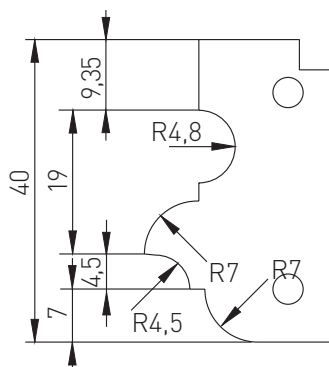
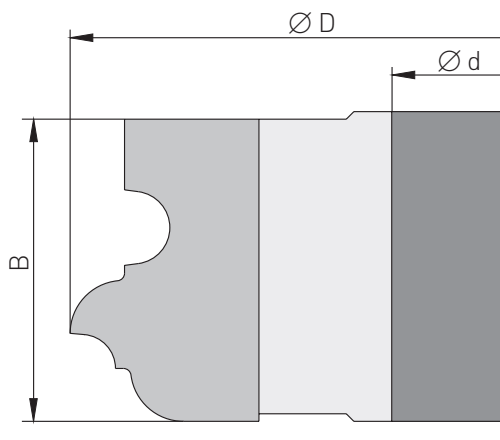

Art.-Nr./item no./num. art. 09.1401

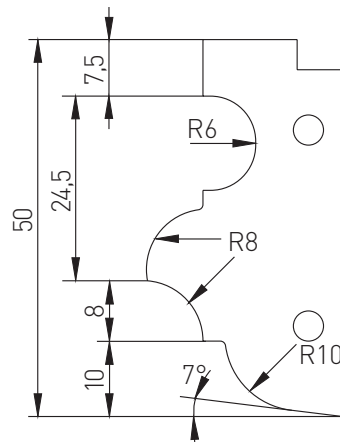

Art.-Nr./item no./num. art. 09.1402

Grundkörper Aluminium
Tool body in light alloy
Corps de base en alliage léger

MAN



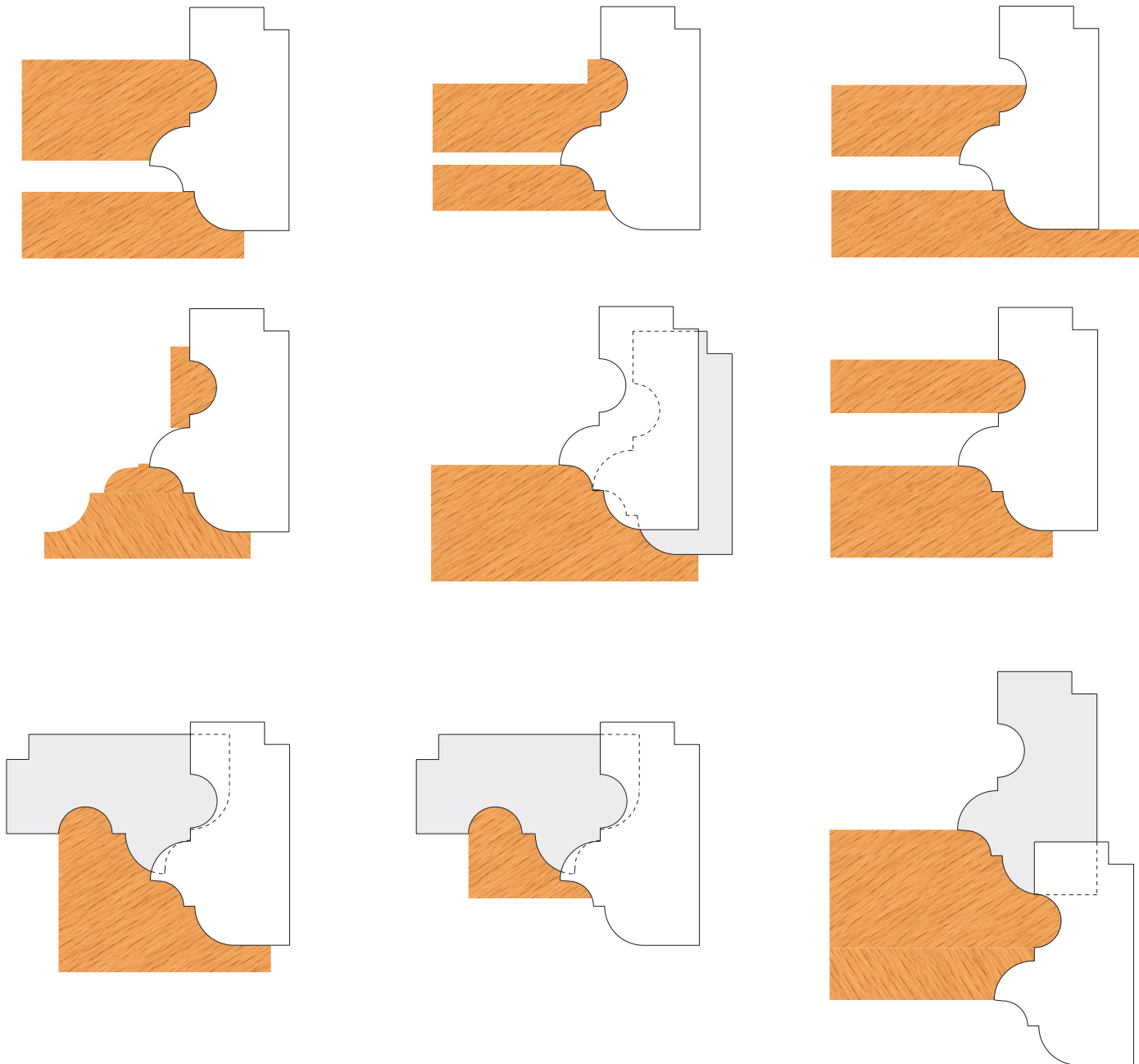

HW-Profilmesser / TC profile knife / plaquette profilée HW

Artikel-Nummer item no./num. art.	Beschreibung/description/description	Abmessung dimensions/dimensions
09.1401	HW-Profilmesser / TC profile knife / plaquette profilée HW	40 x 25 x 2 mm
09.1402	HW-Profilmesser / TC profile knife / plaquette profilée HW	50 x 27 x 2 mm

Ersatzteile / spare parts / pièces de rechange:

	HW-Profilmesser TC profile knife plaquette profilée HW	Spannkeil wedge coin de serrage	Gewindestift threaded pin goujon fileté	Anschlagschraube stop screw vis-butée	Sechskant-Stiftschlüssel allen wrench clé mâle à 6 pans
Art.-Nr. / item no. / num. art. 14.120.040.030.A					
Art.-Nr./item no./num. art.	09.1401	09.0040	DIN 915-45H-6X16	DIN 921-4.8-4X8	DIN 911-ST-3
Abmessung/dimensions/dimensions	40 x 25 x 2 mm	38 x 8 x 12 mm	M 6 x 16	M 4 x 8	SW 3
Preis/price/prix €					
Art.-Nr. / item no. / num. art. 14.160.050.030.A					
Art.-Nr./item no./num. art.	09.1402	09.0041	DIN 915-45H-6X16	DIN 921-4.8-4X8	4.09.31000240
Abmessung/dimensions/dimensions	50 x 27 x 2 mm	48 x 8 x 12 mm	M 6 x 16	M 4 x 8	SW 3
Preis/price/prix €					