

Abplattfräser Raised panel bits

Schneidet alle Verbundwerkstoffe, Sperrholz, Hartholz und Weichholz. Einsatz nur an tischmontierten tragbaren Fräsmaschinen.
Zum Abtragen großer Materialmengen in mehreren Durchläufen.

Cuts all composites, plywood, hardwood and softwood. Use only on table mounted portable router machines.
Use multiple passes when removing large quantities of material.

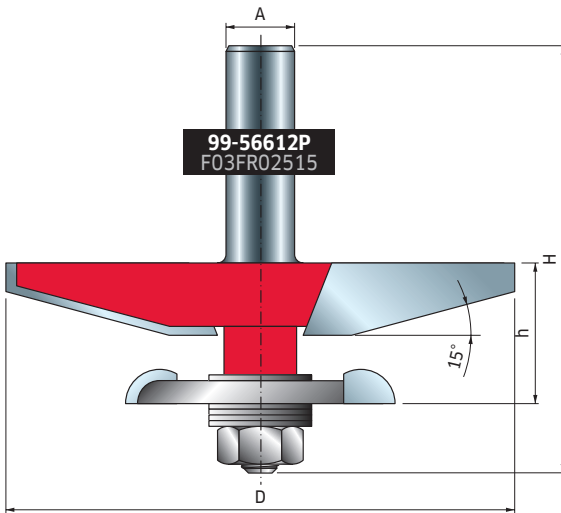

D	h	H	A	R1	R2	Z	Max. Drehzahl Max RPM	Code	SAP
mm	mm	mm	mm	mm	mm			Code	SAP
89	25	75	12	6	2	2	14.000	99-56612P	F03FR02515
89	25	75	12	38	6	2	14.000	99-56912P	F03FR02523
89	25	75	12	30	6	2	14.000	99-57112P	F03FR02529

Ersatzteile Spare parts		Maße Dimensions mm	Code Code	SAP SAP
	Sechskantmutter / Hex nut	7,94 x 6,75	2610M BB9	F03F010003
	Distanzring / Spacer	18 x 0,1 x 8	AN01MP0019	F03FC00392
	Distanzring / Spacer	18 x 0,2 x 8	AN01MP0029	F03FC00393
	Distanzring / Spacer	18 x 0,5 x 8	AN01MP0059	F03FC00395
	Distanzring / Spacer	18 x 1 x 8	AN01MP0109	F03FC00396
	Distanzring / Spacer	18 x 0,15 x 8	AN01MPAA99	F03FC00391

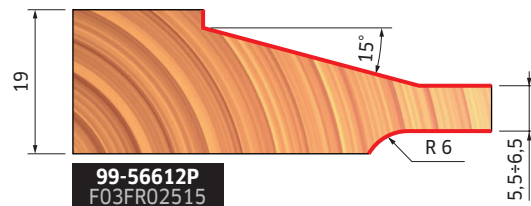
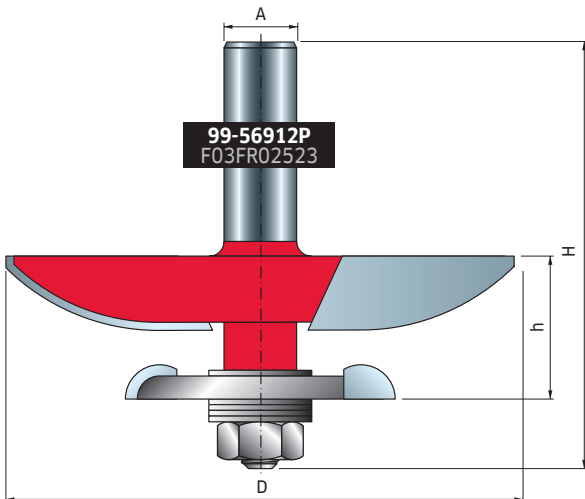

99-56612P
F03FR02515

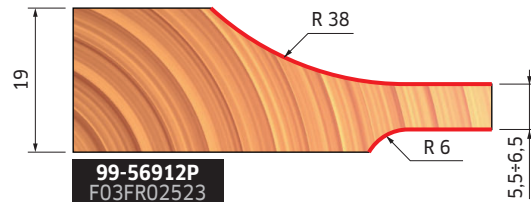

99-56912P
F03FR02523

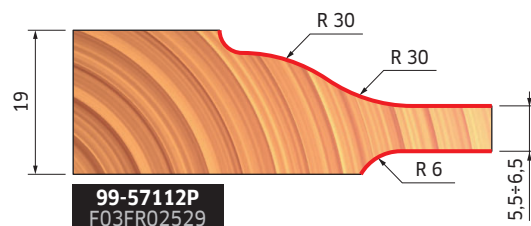
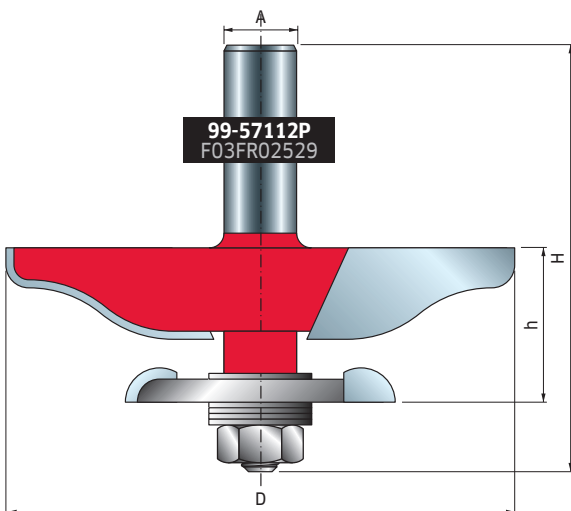

99-57112P
F03FR02529

Zum Herstellen von Abplattungen fräsen Sie die Türfüllung auf allen vier Seiten. **Stellen Sie hierbei aber sicher, dass die beiden Seiten, auf denen die Fasern quer zur Arbeitsrichtung verlaufen, zuerst gefräst werden.**

To produce the inner raised panel router the panel on all four sides but ensure that **the two across vein sides are routed first.**

